

Series 950MD Mill-Duty Housing

The series 950 Mill-Duty Housing (950MD) was designed for applications where mounting a stand-alone rod style linear displacement transducer (LDT) is prohibitive. Potential physical damage, environmental conditions or mounting limitations are all elements that are involved in specifying a linear position feedback system that will perform flawlessly for many years to come. The 950MD housing has been designed to eliminate all of the above problems by protecting the LDT from physical and environmental damage such as temperature, corrosives, shock & vibration, or dust and debris. Additionally, the 950MD offers a simple two point mounting scheme that can compensate for lateral and/or horizontal movement of the machine while in operation. Mounting bolts are provided for both the trunnion mount and rod ends in either standard steel or optional Stainless Steel when specified.

The 950MD housing is also perfect for retrofitting existing cylinders with an LDT providing a continuous position feedback signal. The 950MD allows for a convenient way to mount the 950MD and internal LDT parallel to the cylinder. This eliminates the need to tear down and gun drill the cylinder to accommodate an LDT simply for providing position feedback that had not previously been available.

The housing may also be of benefit in this same configuration when you have an existing cylinder in operation that does not allow for an easy removal of the LDT. Old machines and even some existing machines or newly designed machines did not take into consideration the need for continuous position feedback. Certain machines may require that the entire cylinder be removed in order to replace the LDT.

The actuator contains a 1/2" spherical rod end with approximately 1" of adjustment (length). This spherical rod end allows mechanical movement in a horizontal and/or vertical motion to compensate for any mechanical slop or misalignment between the housing and machine. A rear trunnion mount is provided for mounting either directly in front of the head assembly or on the rear of the head. An optional 3/4" spherical rod end can be supplied on the rear of the unit (see drawing for details).

The back cap is supplied with threaded and plugged holes that allow for field installation of the 3/4"



diameter trunnion mount bracket to the back cap. The trunnion mount bracket is positioned at the point where the head and barrel connect. A simple exchange of hardware is all that is necessary to move the trunnion mount bracket to the back cap and plug the no longer required bracket mounting holes. When ordering the 3/4" rear rod end option, the trunnion mount bracket is not supplied since it would not be required.

The actuator rod is supported by two bearings within the guide tube. The front piston bearing contains a wiper assembly to keep contaminants from entering the guide tube. The rear, or movable, bearing assembly is manufactured from Rulon®. This high-temperature polymer material provides low wear and smooth operation.

The transducer magnet is mounted within the rear bearing assembly. The magnet is a 1" O.D. cylinder magnet (SD0410300). The magnet is positioned 2" from the end of the transducer hex when the actuator is fully retracted and 5" from the end of the transducer guide tube when the actuator is fully extended.

The 950MD is designed to incorporate an LDT which has a minimum 2" Null Zone and 5" Dead Band.

950MD Mill-Duty Housing

Due to the fact that the standard Mill-Duty Housing has a mechanical stroke identical to the LDT active stroke, no physical over-stroke exists. If it is possible that the machine being coupled to can extend/retract beyond the stroke supplied, damage to the Mill-Duty Housing and possibly to the machine might occur. To compensate for this we call out fully retracted/fully extended over-stroke dimensions for the Mill-Duty Housing. These values are essentially the additional stroke length added to the Mill-Duty Housing. The reason they are called out separately is to alert the user that when entering these areas, they are out of the LDT active stroke area. If an extended over-stroke is specified, the LDT must be ordered with a Dead Band of 5" + X (extended stroke value). If a retracted over-stroke is specified, the LDT must be specified with a Null value of 2" + Y (retract over-stroke value).

The Mill-Duty Housing offers either a conduit entrance for hard wiring directly to the LDT within the head or an external connector and mate. The connector attaches to the LDT inside of the housing via a small pigtail connector within the head.

Detailed Product Description and Materials of Construction

The 950MD consists of a 304 Stainless Steel body, barrel, piston, head and trunnion mount bracket.

The standard 1/2" diameter rod end with mounting bolt, the 3/4" diameter trunnion mounting bolt, and some of the optional MS connectors on the head are the only items that are not Stainless Steel on the standard assembly. This is also true of the optional 3/4" diameter front and rear rod ends with their mounting bolts. These rod ends and all mounting bolts can be ordered in Stainless Steel as an option. The 12mm Euro connector options C3 and C4 come standard in Stainless Steel. Consult the factory for further details.

The 950MD head assembly is removable to allow installation of a rod style LDT that will screw into the standard 3/4" - 16 x 1.00 mounting thread. An optional Metric thread of M18 X 1.5 can also be supplied upon request. The head contains a 1/2"



950MD

NPT conduit port for wiring to the LDT or optionally an MS connector can be installed for the external wiring. Use of the MS connector will require that the LDT also have a connector on it in lieu of a potted cable. This will allow for a quick connect at the LDT head internally and on the 950MD head externally. The 950MD head is sealed with O-rings and also contains two threaded air purge openings that are plugged but available for use to air cool the LDT head with filtered and regulated air. By removing the plugs and installing the proper size air fittings, you can cool the head electronics for high temperature applications. An optional Vortex air cooler may also be specified for the head and/or barrel or an optional water jacket for the LDT can be supplied. See the 950MD dimension drawings for further details.

**Consult Factory if installing
950IS or ReadyLink™ Network LDT
into 950MD Housing**

950MD Mill-Duty Housing

Applications

The 950MD was originally designed for use in steel mill applications but has proven to be reliable in many applications where ruggedness, environmental protection and ease of mounting are required. Some of these applications include:

Steel Mills - Tundish car (Tundish height), turret height (Caster), hydraulic coil cars, torch cutoff machine (torchhead monitoring), furnace tilt, electrode positioning, side guide positioning, ladle slide gate positioning, louver or roof position, etc.

Foundries, Forging and Casting – Linear transducers with 950MD housings have been used on sand mold compactors, furnace or oven doors and material transfer systems.

Injection Molding and Die Casting – Proven effective in monitoring/controlling the position of the clamp and/or shot cylinder. The two point connection of the 950MD housing allows for a simple retrofit by replacing limit switches with an LDT for position feedback over the entire range movement. Linear potentiometers can also be replaced, thus eliminating their problems with drift, temperature, and short life span.

Hydraulic Servo Applications - Ideal for installing parallel to hydraulic cylinders including new applications and retrofits. The major advantage to using the 950MD housing versus gun drilling the cylinder for an LDT is that the cylinder fluid flow is not compromised. If an LDT fails within a cylinder it cannot be removed without having to deal with the hydraulic fluid lines, pressure etc. Some cylinders may be difficult to remove once installed, thus inhibiting the removal of the LDT. The 950MD housing is typically mounted parallel to the cylinder, the same as a slave cylinder would be, so removal is greatly simplified under these conditions.

Lock and Dam Sites - Miter gate and Tainter valve position feedback systems have both benefited from the 950MD and LDT combination.

Gate Position Feedback - For hydro-electric plants, water control structures, water and wastewater treatment and managing, wicket gate position feedback for Turbine speed control.

Optional Items

The standard Mill-Duty Housing includes the complete

housing assembly with provisions to accept an LDT and all bolts, nuts and mounting hardware required for a complete installation. There are also several optional items available.

Vortex Air Cooler - The standard 950MD is equipped with air purge ports. In many cases, running clean shop air through the head is sufficient to cool the electronics. For severe temperature applications a Vortex Air Cooler may be desired. A Vortex Air Cooler accepts standard shop air (80 - 100 PSIG). The air is ejected through a generator in a Vortex spin chamber where the air stream revolves in a tube at up to 1,000,000 RPM. In simplest terms the inner stream gives off energy in the form of heat to the outer stream and the inner stream exits the opposite end as hot air. The Vortex Cooler is capable of generating air flows as cold as -40° F.

Protective Boots - To give added protection to the actuator rod, protective boots are available. These boots attach between the end of the Mill-Duty guide tube and the end of the actuator rod assembly. The boots are offered in neoprene coated nylon for most standard applications. They offer -60° F to 250° F operating range with resistance to water and oil. Also, silicone coated fiberglass offers high temperature resistance from -100° F to 550° F; Teflon-coated fiberglass offers -100° F to 500° F operating range with a high degree of corrosion resistance and optional stainless steel boots for rugged applications.

Water-Cooled Head Assemblies - In applications where extreme temperatures are present and air cooling is not appropriate, water-cooled head assemblies are available. Cooling jackets within the head assembly allow water to flow around the electronics.

Front and Rear Mount Spherical Rod Ends - In applications where two spherical rod ends are required, rear mount spherical rod ends are available. The 3/4" rear rod end attaches to a threaded bolt extending from the rear of the head. The 3/4" front rod end is threaded into the piston rod. An optional stainless steel version is available. Mounting bolts are supplied with both versions.

Delrin Liner - Used in longer horizontal applications, typically 60" or longer to prevent wear on the LDT's guide tube as the 950MD housing is stroked. The Delrin liner is installed inside of the 950MD barrel and prevents sag of the LDT's guide tube.

950MD Mill-Duty Housing Part Numbering

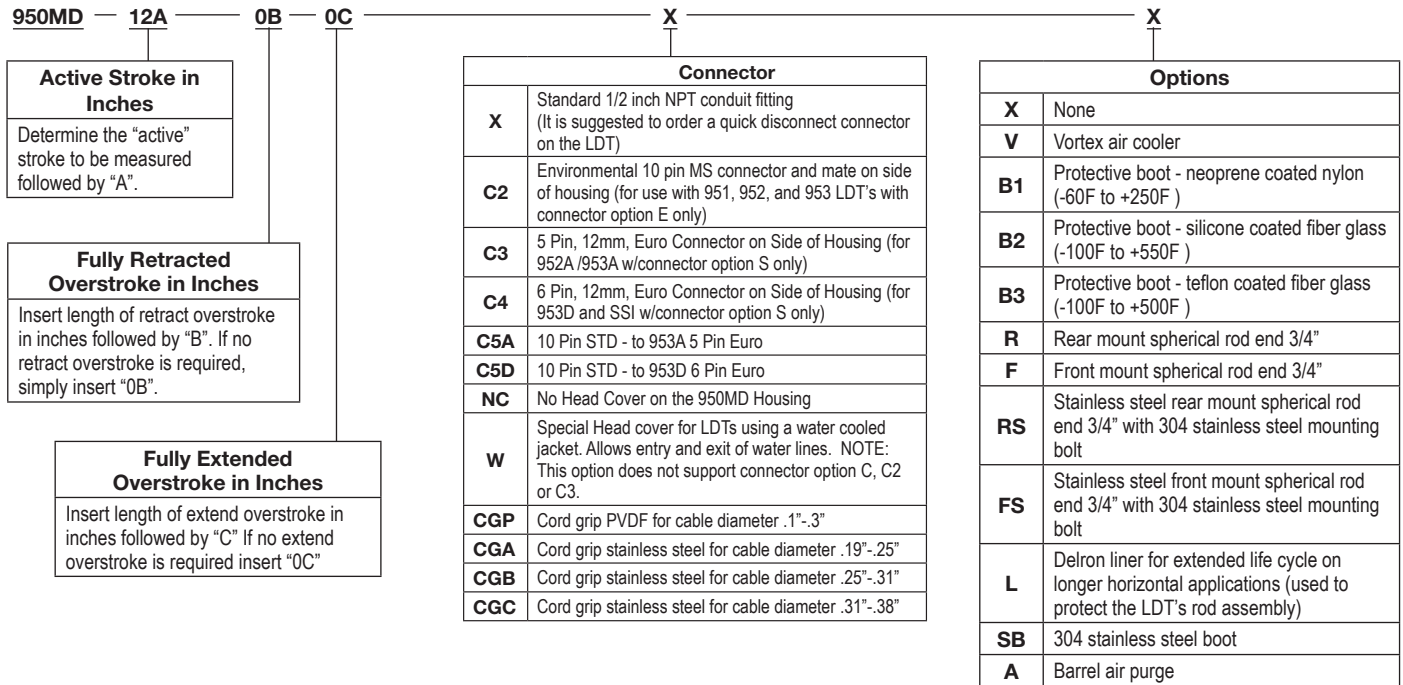

950MD

Note 1: Guide tube support brackets are supplied as standard for strokes of 72" or greater.
Note 2: Special high temperature, abrasion resistant and oil resistant cables are available. Consult your Customer Service Representative.

950MD Compatibility Guide	
940	Yes
950IS	Consult Factory
951	Yes (Should be ordered w/2" Null Zone & 5" Dead Band)
952	Yes (Should be ordered w/2" Null Zone & 5" Dead Band)
953	Yes (Should be ordered w/2" Null Zone & 5" Dead Band)
955	See 956 Section
7330	Consult Factory
ReadyLink™	Consult Factory

Accessories	
Item	Part Number
Vortex Cooler	04578009
Muffler for Cooler	04578010
Replacement 1/2" Spherical Rod End	04570140
Guide Tube Support Bracket (See note 1)	C0903400
Replacement (Male Connector) for Option "C2" Connector	04521407
Female Mating Connector for Option "C2" Connector	04521372
Replacement (Male Connector) for Option "C3" Connector	04521568
Replacement Piston & Magnet Sub Assembly	SD0452400
Replacement Housing bushing & Seal Sub Assembly	SD0563300

951, 952 and 953 LDT Cable Assemblies	
Item	Part Number
Cable Assembly with Mate for Option "C2", C5S, and C5D Connector Styles, 6 Feet	SD0439700L6
5 Pin, Straight, Stainless Steel Cable Assembly with Mate for Option "C3" Connector Style, 6 Feet	949013L6
6 Pin, Straight, Stainless Steel Cable Assembly with Mate for Option "C4" Connector Style, 6 Feet	949031L6

950MD Mill-Duty Housing Standard 950MD

NOTES: UNLESS OTHERWISE SPECIFIED

1. DIMENSIONS IN BRACKETS [mm] ARE IN MILLIMETERS.
2. FOR LDT OUTPUT SIGNAL CHARACTERISTICS IN THE OVERSTROKE ZONES, SEE APPROPRIATE LDT CATALOG SECTION.

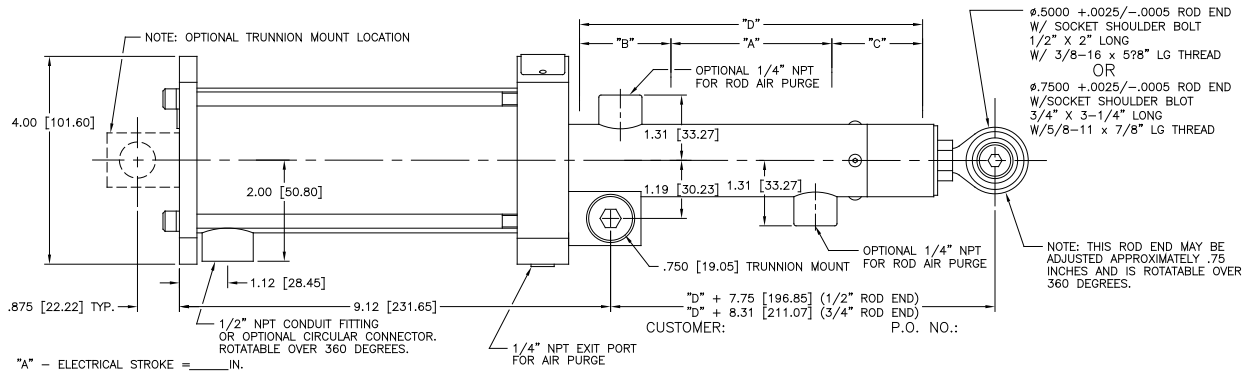
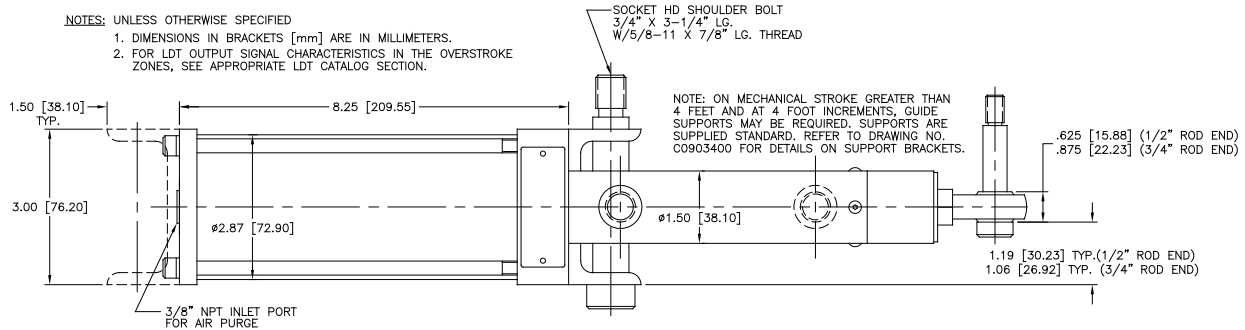

- "A" - ELECTRICAL STROKE = ____ IN.
 "B" - RETRACTED OVERSTROKE = ____ IN.
 STANDARD = 0 IN.
 "C" - EXTENDED OVERSTROKE = ____ IN.
 STANDARD = 0 IN.
 "D" - TOTAL MECHANICAL STROKE = ____ IN.
 SUMMATION OF A,B, & C.

Mill-Duty with Rear Mount Spherical Rod End

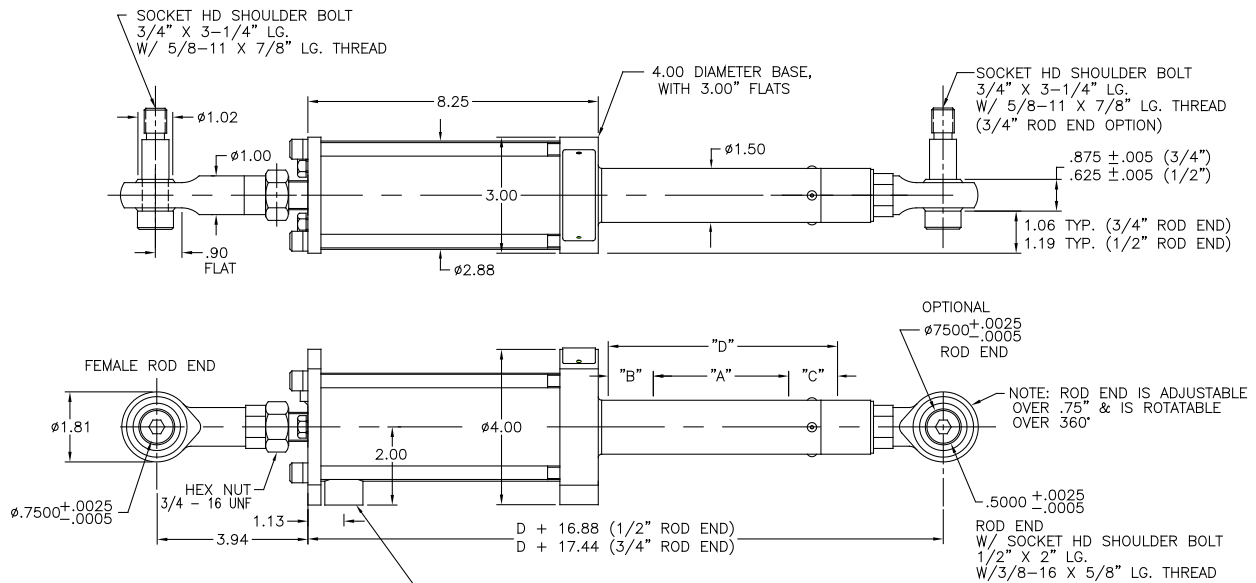

- "A" - ELECTRICAL STROKE = ____ in.
 "B" - RETRACTED OVERSTROKE = ____ in.
 STANDARD IS 0 in.
 "C" - EXTENDED OVERSTROKE = ____ in.
 STANDARD IS 0 in.
 "D" - TOTAL MECHANICAL STROKE = ____ in.
 SUMMATION OF "A"+"B"+"C"

950MD