



# INDUSTRIAL LUBRICATION FITTINGS



- ▶ Threaded/Drive Fittings
- ▶ Corrosion Resistant Fittings
- ▶ Standard/Metric Fittings
- ▶ Specialty Fittings
- ▶ Vents/Breathers
- ▶ Fitting Assortments
- ▶ Fitting Accessories

As the inventor of the Zerk fitting, Alemite is a recognized global leader in supplying fittings for automotive and industrial use. Alemite fittings conform to SAE J534 standards for automotive OEM use, and Alemite's manufacturing is TS/ISO 16949 certified.

- ▶ P.T.F. SAE short taper pipe thread.
- ▶ N.P.T.F. American National taper pipe thread for Dryseal pressure-tight joints.
- ▶ N.P.S.M. American National straight pipe thread for mechanical joints.
- ▶ N.P.S.I. American National straight intermediate pipe thread.

## THREADED FITTINGS

### 1/4"-28 Taper Thread Fittings

ALEMITE 1/4"-28 Taper Thread Fittings are used on most cars and trucks, as well as many industrial machines. It is recommended that SAE-LT taper threads be assembled into 1/4"-28 UNF, Class 3B, straight threaded holes having a modified maximum minor diameter of 0.2151", to ensure 75% minimum thread height.

**FEATURES:**

- Exceeds 72 hour salt spray test
- Dirt excluding check ball
- Trivalent zinc plating
- RoHS compliant

Product #	Type	Hex Size	Overall Length	Shank Length
1641-B	Straight	5/16"	35/64"	3/16"
1652-B	Straight	5/16"	11/16"	23/64"
1680-B	Straight	5/16"	31/32"	5/8"
1698-B	Straight	5/16"	1-1/8"	25/32"
3014-B	Straight	5/16"	1-5/8"	1"
1637-B1	45°	3/8"	13/16"	13/64"
3010-B1	65°	3/8"	25/32"	19/64"
1911-B1	90°	3/8"	3/4"	13/64"

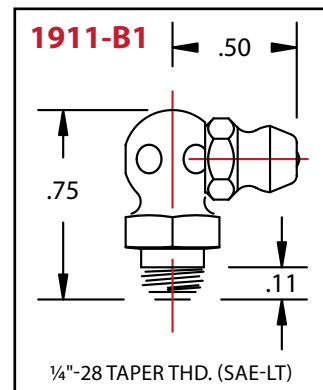
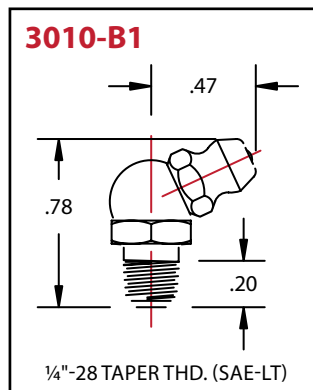
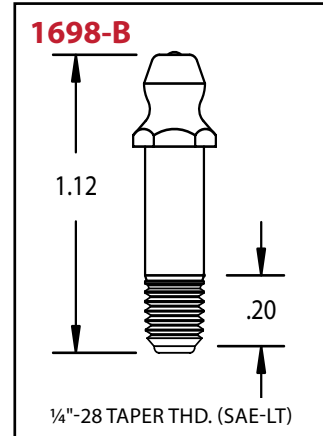
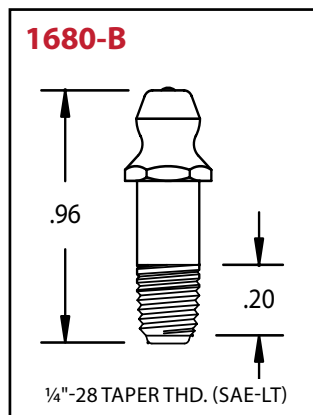
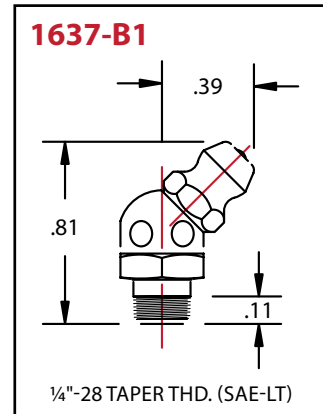
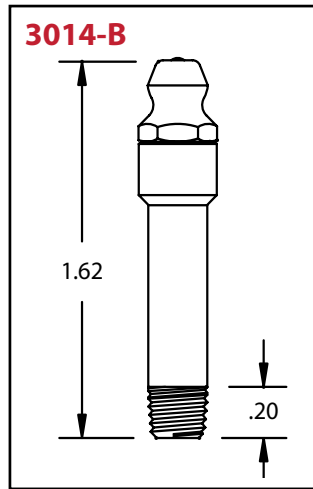
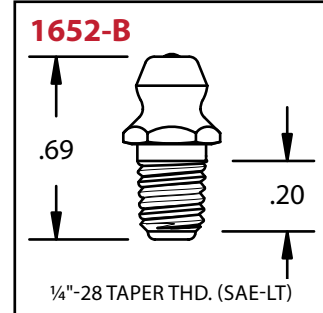
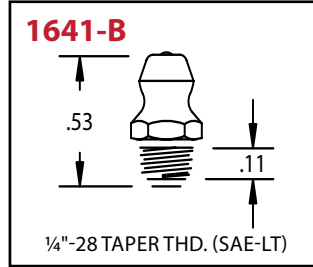

## THREADED FITTINGS

### 1/4"-28 Straight Thread Fittings

Alemite 1/4"-28 Straight Thread Fittings are used on most cars and trucks, as well as many industrial machines.

**FEATURES:**

- Exceeds 72 hour salt spray test
- Dirt excluding check ball
- Trivalent zinc plating
- RoHS compliant

Product #	Type	Hex Size	Overall Length	Shank Length
1792-B	Straight	9/32"	33/64"	5/32"
1770-B1	45°	3/8"	39/64"	1/8"
369609	Straight	5/16"	7/16"	1/8"

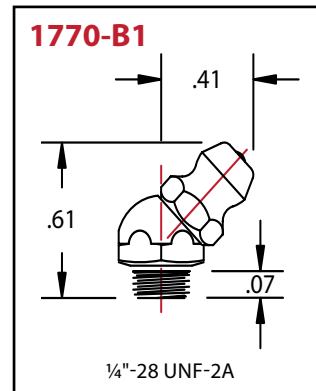
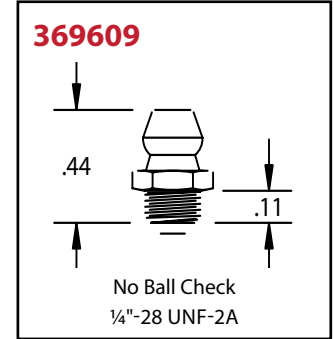
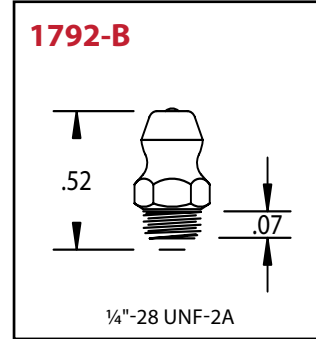



## THREADED FITTINGS

### 1/8" PTF Fittings

Alemite 1/8" PTF Fittings are used on industrial machines and heavy equipment.

**FEATURES:**

- Exceeds 72 hour salt spray test
- Dirt excluding check ball
- Trivalent zinc plating
- RoHS compliant
- 1958 has specialty cap providing a second seal for dust proof applications

Product #	Type	Hex Size	Overall Length	Shank Length
1644-B	Straight	7/16"	9/16"	15/64"
1610-BL	Straight	7/16"	11/16"	19/64"
1607-B	Straight	7/16"	1-1/4"	25/32"
1669-B	Straight	7/16"	1-3/4"	1-17/64"
1684-B	Straight	3/8"	2-5/8"	2-3/16"
1618-B	Straight	1/2"	1"	9/32"
1958 <sup>(1)</sup>	Straight	7/16"	31/32"	1/4"
1611-B	30°	7/16"	29/32"	19/64"
1638-B	30°	7/16"	2-3/32"	1-1/4"
1688-B	45°	7/16"	57/64"	19/64"
1620-B	45°	7/16"	1-1/8"	13/32"
1612-B	65°	7/16"	27/32"	19/64"
1623-B	65°	7/16"	1-7/32"	9/16"
1649-B	65°	3/8"	2-3/4"	2-1/4"
1613-B	90°	7/16"	27/32"	19/64"
1606-B	90°	7/16"	1-13/16"	1-1/4"
369599	Straight	7/16"	2-5/8"	7/32"
369608	65°	7/16"	29/32"	9/32"
369574	Double 70°	1/2"	27/32"	7/32"

<sup>(1)</sup>Also available in a 1/8" BSPT version (1958-E)

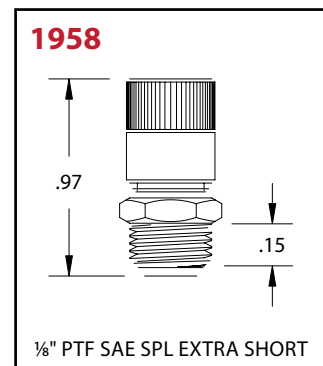
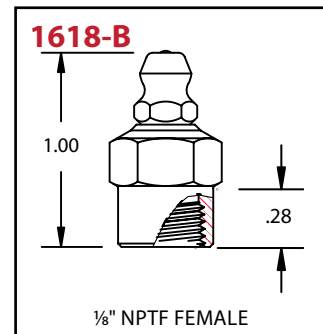
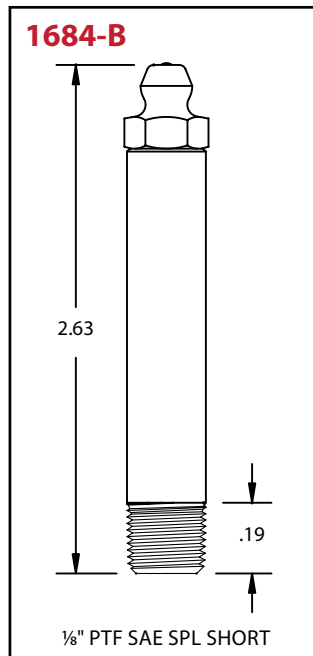
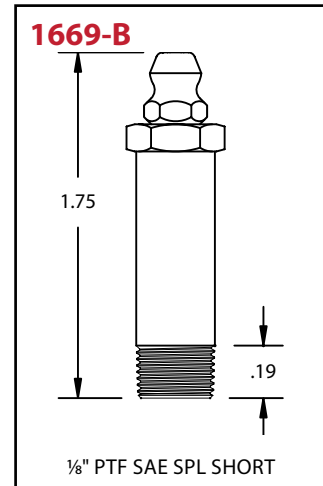
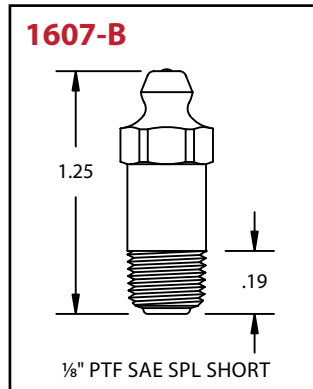
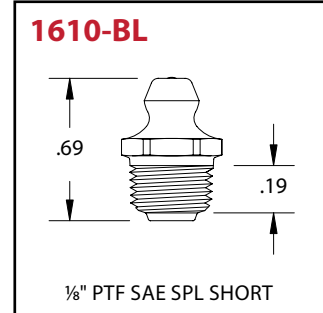
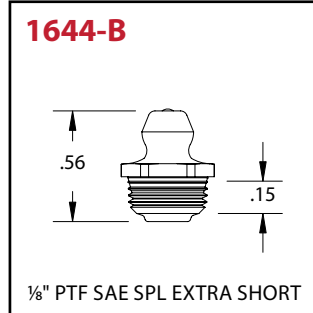

# INDUSTRIAL LUBRICATION FITTINGS

## THREADED FITTINGS

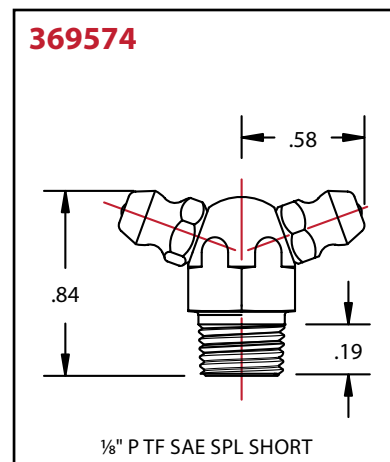
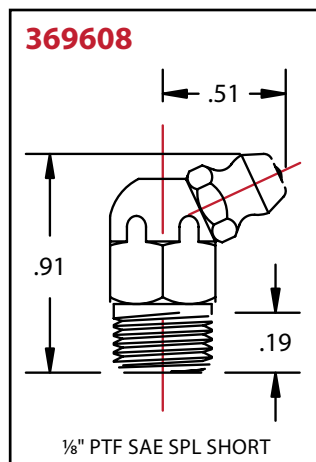
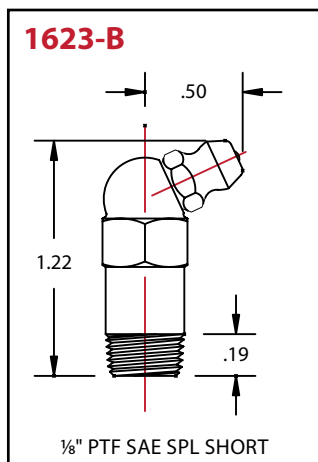
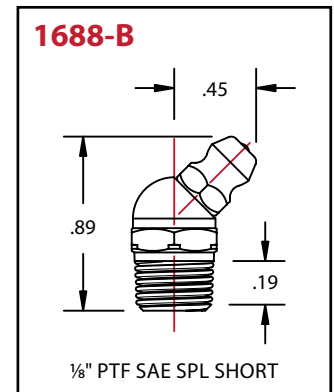
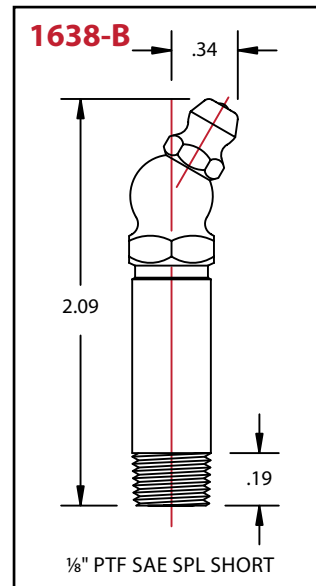
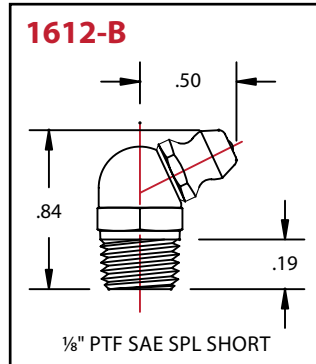
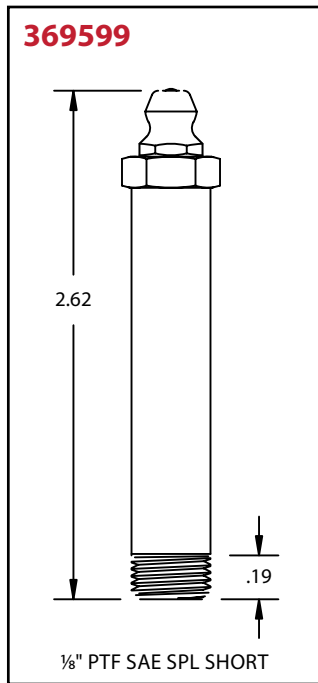
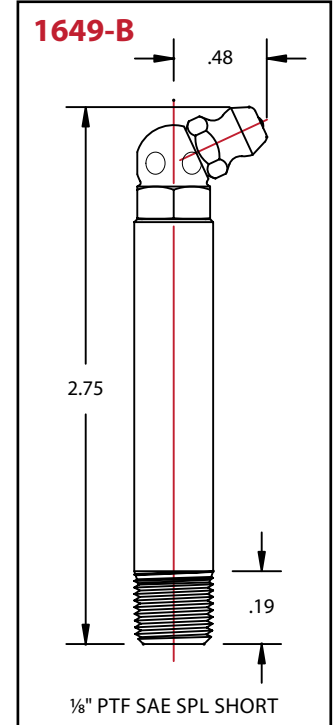
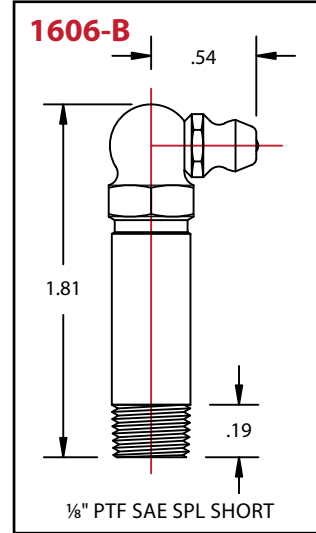
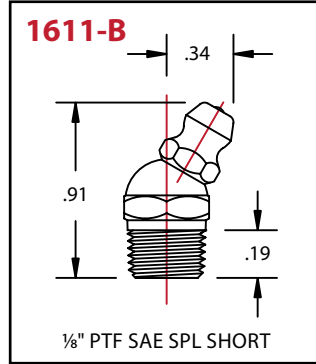
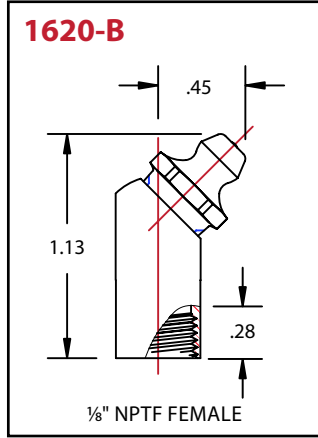

## THREADED FITTINGS

### 1/4" PTF Fittings

Alemite 1/4" PTF Fittings are widely used for larger bearings on farm machinery and heavy industrial equipment. Recommended for heavy lubricants in cold weather.

**FEATURES:**

- Exceeds 72 hour salt spray test
- Dirt excluding check ball
- Trivalent zinc plating
- RoHS compliant
- Dry seal eliminates need for sealant

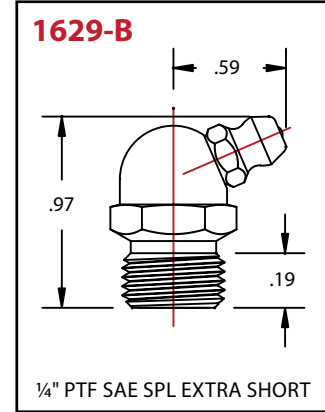
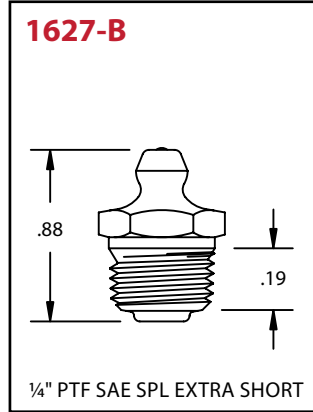

Product #	Type	Hex Size	Overall Length	Shank Length
1627-B	Straight	9/16"	7/8"	27/64"
1629-B	67.5°	9/16"	31/32"	11/32"

## THREADED FITTINGS

### 1/4"-28 and 1/8" Thread Forming Fittings

Alemite Thread Forming Fittings have special tapered drive threads which reshape the material in an untapped hole to provide a leak proof seal. They are most effectively installed by spinning into the untapped hole. Thread forming fittings can be replaced by any standard threaded fitting or by another thread forming fitting.

**FEATURES:**

- Exceeds 72 hour salt spray test
- Dirt excluding check ball
- Threads provide strong seal
- Dyed yellow for identification
- Trivalent zinc plating
- RoHS compliant

Product #	Type	Hex Size	Hole Size recommended
3038-B	Straight	5/16"	.230 - .235
3053-B	45°	3/8"	.230 - .235
3054-B	90°	3/8"	.230 - .235
1720-B	Straight	7/16"	.373 - .380
1723-B	90°	7/16"	.373 - .380
1724-B	45°	7/16"	.373 - .380
369582	Straight	9/32"	.230 - .235

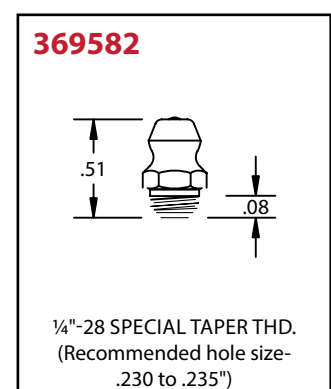
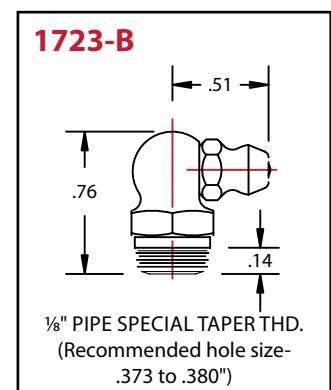
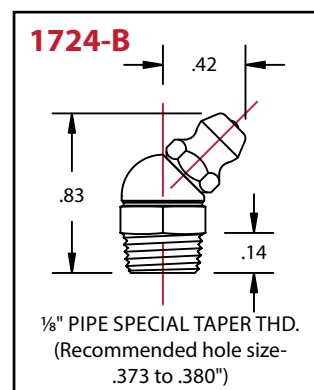
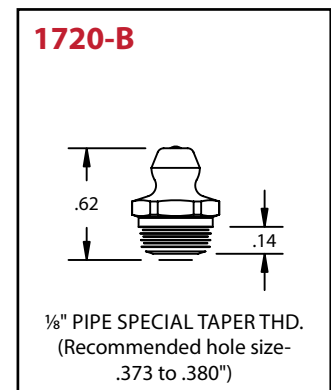
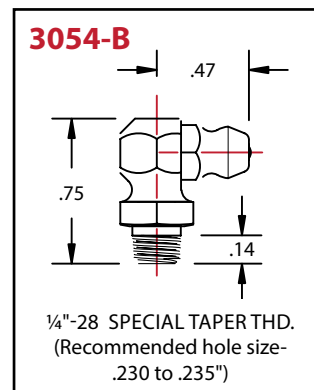
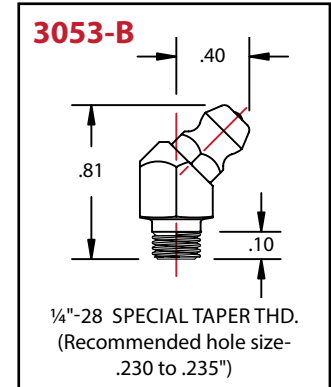
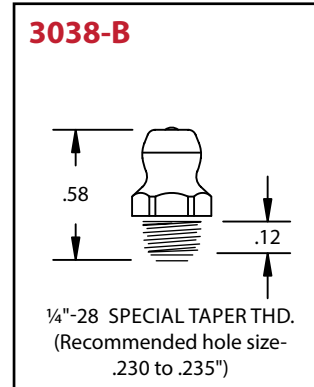



## CORROSION RESISTANT FITTINGS

### Monel Fittings

Alemite Monel Fittings withstand the most severe marine and industrial corrosive environments. Monel is a Nickel/Copper alloy that is highly resistant to corrosion. All monel fittings have a single notch on the hex for easy identification.

**FEATURES:**

- Greater corrosion resistance than stainless steel
- Withstands extreme temperatures ranging from sub-zero to 700°F (371°C)
- Ideal for use in harsh chemical environments and marine applications
- Dirt excluding check ball
- RoHS compliant

Product #	Thread	Type	Hex Size	Overall Length	Shank Length
1966-B	1/4"-28 Taper	Straight	5/16"	17/32"	3/16"
1969-B	1/4"-28 Taper	90°	3/8"	3/4"	13/64"
1962-B	1/8" PTF	Straight	7/16"	5/8"	9/32"
1961-B	1/8" PTF	Straight	7/16"	3/4"	5/16"
1921-B	1/8" PTF	30°	7/16"	1-1/4"	11/32"
1922-B	1/8" PTF	67.5°	7/16"	61/64"	11/32"
1923-B	1/8" PTF	90°	7/16"	7/8"	11/32"

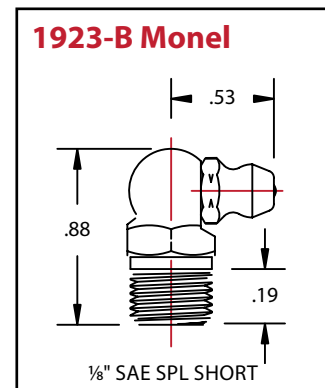
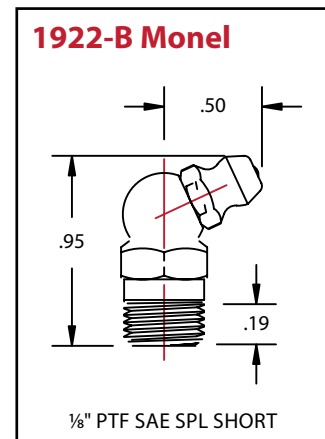
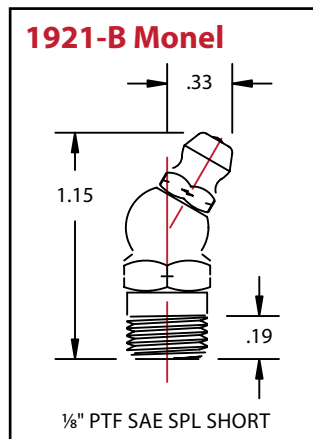
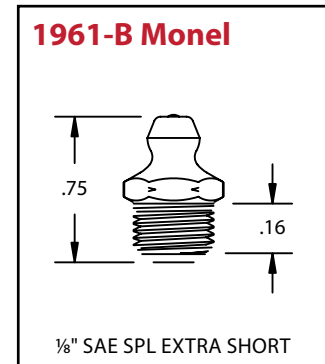
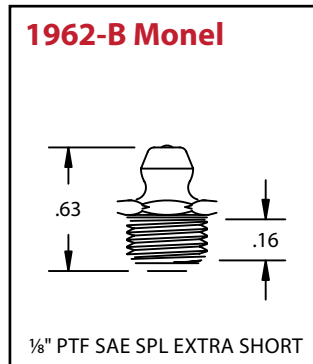
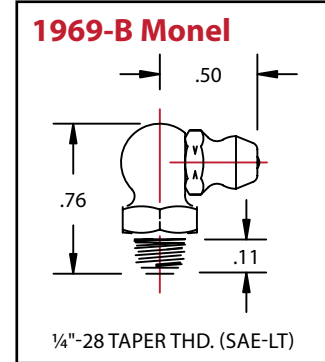
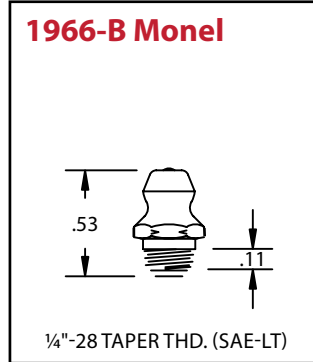



# INDUSTRIAL LUBRICATION FITTINGS

## CORROSION RESISTANT FITTINGS

### Stainless Steel Fittings

Alemite Stainless Steel Fittings withstand severely corrosive marine and industrial environments. All stainless steel fittings have 2 notches for easy identification.

**FEATURES:**

- Greater corrosion resistance than carbon steel
- Withstands extreme temperatures ranging from sub-zero to 600°F (315°C)
- Ideal for use in harsh chemical environments and marine applications
- Stainless steel fittings are comprised of Type 303 SS for fitting bodies, Type 440 SS for balls, and Type 302 for tempered springs
- Dirt excluding check ball
- RoHS compliant

Product #	Thread	Type	Hex Size	Overall Length	Shank Length
1966-S	1/4"-28 Taper	Straight	5/16"	17/32"	3/16"
1968-S	1/4"-28 Taper	45°	3/8"	13/16"	13/64"
1969-S	1/4"-28 Taper	90°	3/8"	3/4"	13/64"
1961-S	1/8" PTF	Straight	7/16"	3/4"	5/16"
1921-S	1/8" PTF	30°	7/16"	1-1/4"	11/32"
1922-S	1/8" PTF	67.5°	7/16"	61/64"	11/32"
1923-S	1/8" PTF	90°	7/16"	7/8"	11/32"
1728-S	Drive	Straight	5/16"	33/64"	5/16"

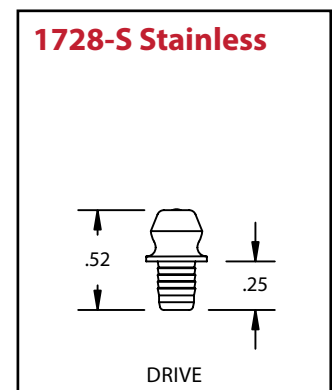
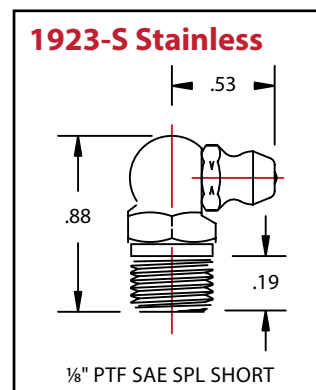
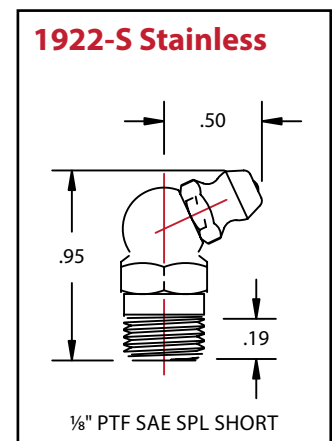
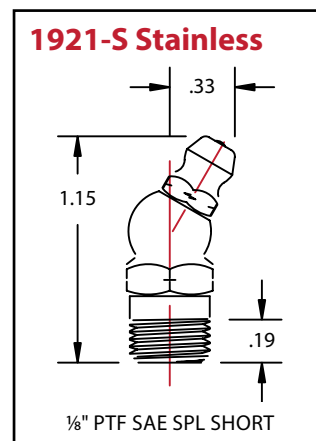
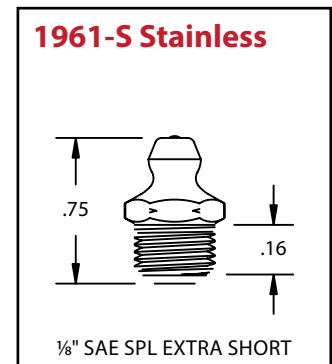
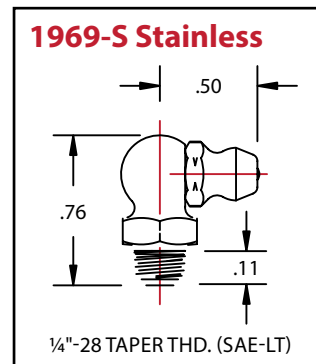
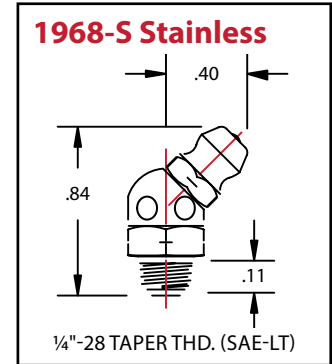
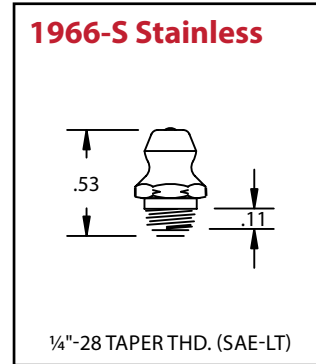

## DRIVE FITTINGS

## Straight

Alemite Drive Fittings provide a simple, cost effective alternative to tapping for various applications.

## FEATURES:

- Exceeds 72 hour salt spray test
- Used for untapped holes
- Serrated shank provides secure, lasting grip
- Simplifies replacement of damaged fittings in old or oversized holes
- Trivalent zinc plating
- RoHS compliant

All fittings clear zinc unless otherwise noted.

Product #	Type	Overall Length	Shank Length	Drill Diameter	Ball Check
1736-A	Straight	9/16" (14.28 mm)	1/4"	1/8"	No
3019	Straight	15/32" (11.91 mm)	5/32"	1/8"	No
3009	Straight	25/64" (9.92 mm)	3/32"	3/16"	No
3005	Straight	15/32"	11/64"	3/16"	No
3006	Straight	31/64"	7/32"	3/16"	No
1728-B	Straight	33/64" (13.09 mm)	1/4"	3/16"	Yes
1633	Straight	5/8"	1/4"	3/16"	No
1743-B	Straight	35/64"	1/4"	1/4"	Yes
1952-A	Straight	15/32"	1/8"	1/4"	No
1608-B	Straight	35/64" (13.89 mm)	1/4"	5/16"	Yes
1666	Straight	37/64"	7/32"	3/8"	No
369591	Straight	21/50"	–	3/16"	No
369604	Straight Flush	11/32" (8.73 mm)	21/64"	1/4"	Yes
369577 <sup>(1)</sup>	Straight	35/64" (13.89 mm)	1/4"	1/4"	Yes

<sup>(1)</sup>Yellow zinc

## Drive Fitting Tools-Straight

Product #	Type of Drive Fitting	Use with Fitting
5253	Straight	1633, 1666, 1720-B, 1736-A, 1952-A, 3005, 3009, 3019, 369591, 369604, 369577
5253-1	Straight	1608-B, 1743-B, 3038-B
5253-3	Straight	1728-B



## DRIVE FITTINGS

### Angled

Alemite Drive Fittings provide a simple, cost effective alternative to tapping for various applications.

**FEATURES:**

- Exceeds 72 hour salt spray test
- Used for untapped holes
- Serrated shank provides secure, lasting grip
- Simplifies replacement of damaged fittings in old or oversized holes
- Trivalent zinc plating
- RoHS compliant

Product #	Type	Overall Length	Shank Length	Drill Diameter	Ball Check
1992-B1	45°	53/64"	7/32"	3/16"	Yes
1646-B1	65°	45/64"	7/32"	3/16"	Yes
1744-B1	65°	49/64"	9/32"	1/4"	Yes
1630-B1	65°	45/64"	7/32"	5/16"	Yes

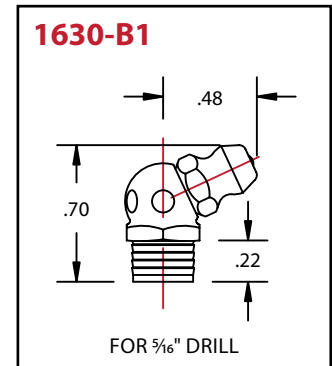
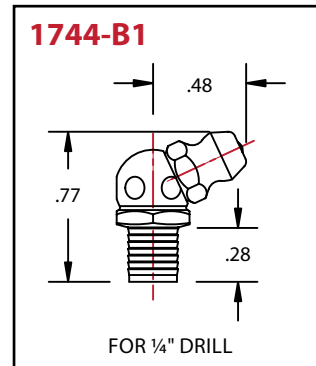
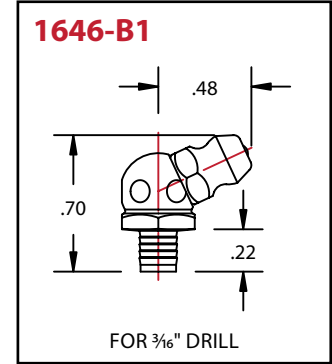
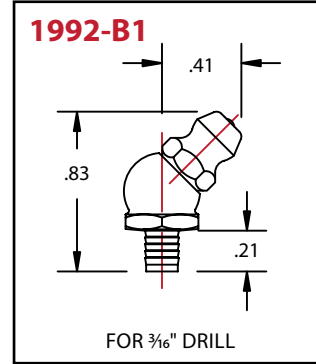

### Drive Fitting Tools-Angled

This special tool simplifies the original installation of drive fittings in untapped holes.

Product #	Type of Drive Fitting	Use with Fitting
5254-1	Angled	1630-B1, 1646-B1, 1744-B1, 1992-B1, 1722-B, 1723-B, 1724-B



**5254-1**



## METRIC FITTINGS

### Threaded Metric Fittings

Alemite metric thread conforms to German Standard DIN 71412.

FEATURES:

- Exceeds 72 hour salt spray test
- Dirt excluding check ball
- Trivalent zinc plating
- RoHS compliant

Prod. #	Thread	Type	Hex Size	Overall Length	Shank Length
2106	6 mm x 1 mm	Straight	7 mm	19/32"	1/4"
2107	6 mm x 1 mm	45°	10 mm	13/16"	7/32"
2108	6 mm x 1 mm	90°	10 mm	3/4"	7/32"
2103	8 mm x 1 mm	Straight	9 mm	5/8"	1/4"
2105	8 mm x 1 mm	90°	10 mm	3/4"	7/32"
2109	10 mm x 1 mm	Straight	11 mm	5/8"	1/4"

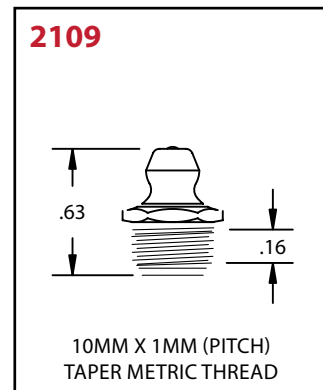
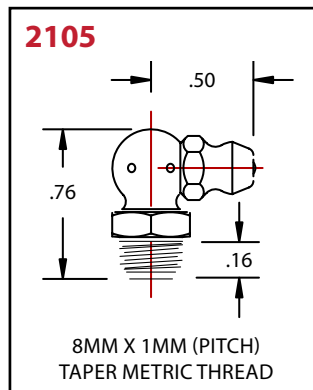
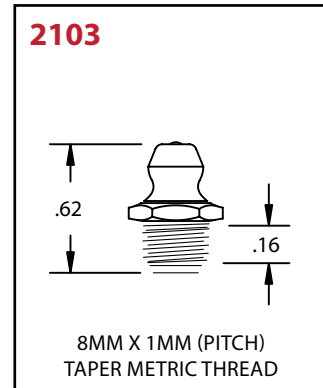
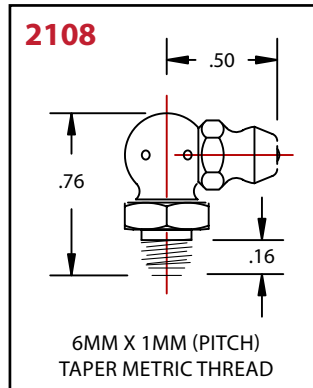
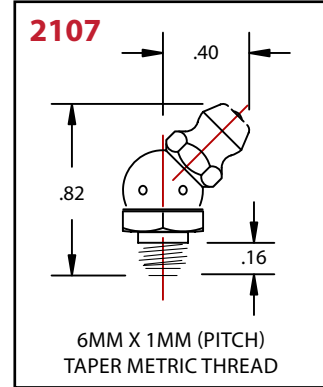
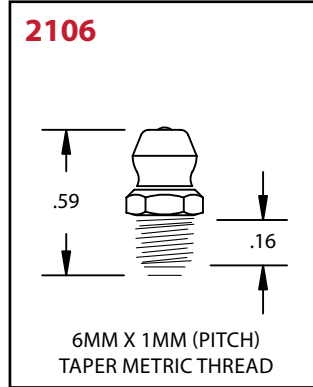

## BUTTON HEAD FITTINGS

### Standard

Alemite Standard Button Head Fittings are used in rugged applications such as heavy machinery, construction equipment and off road equipment.

**FEATURES:**

- Exceeds 72 hour salt spray test
- Trivalent zinc plating
- RoHS compliant
- Head size helps minimize breakage
- Dirt excluding plunger check valve helps reduce dirt contamination

Product #	Thread	Hex Size	Overall Length	Shank Length
A1184	1/8" PTF	5/8"	3/4"	11/32"
A1186	1/4" NPTF	5/8"	53/64"	27/64"
A1188	3/8" NPTF	3/4"	61/64"	31/64"
A1190	1/2" NPTF	7/8"	1-1/16"	35/64"
C69	1/8" NPTF(f)	5/8"	31/32"	13/32"
M1184	1/8" PTF	5/8"	3/4"	11/32"

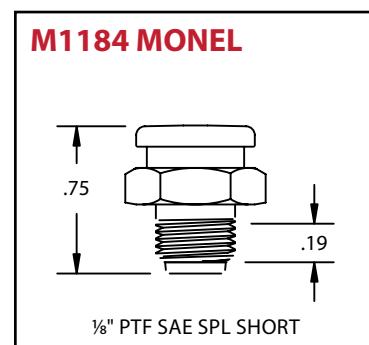
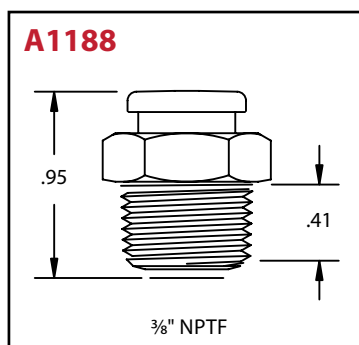
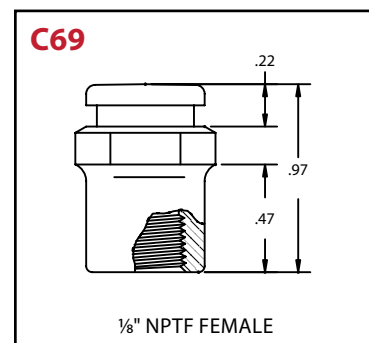
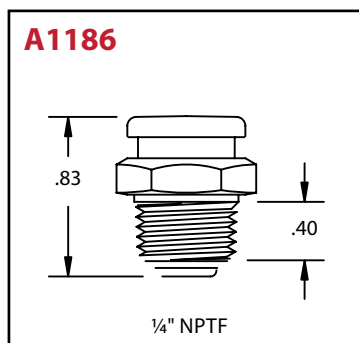
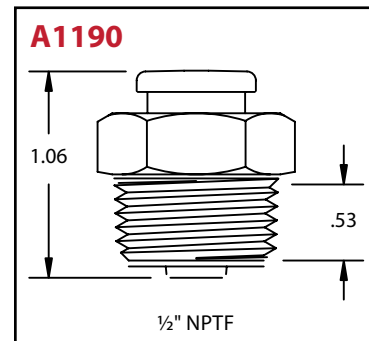
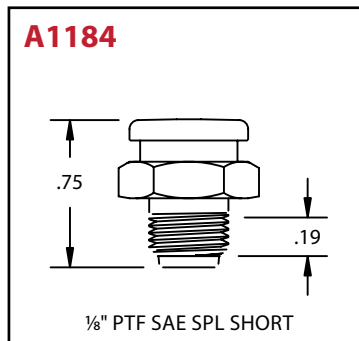



## BUTTON HEAD FITTINGS

### Giant Fittings

Alemite Giant Button Head Fittings are the largest fitting available for rugged applications.

FEATURES:

- Exceeds 72 hour salt spray test
- Trivalent zinc plating
- RoHS compliant
- Head size helps minimize breakage
- Dirt excluding plunger check valve helps reduce dirt contamination

Product #	Thread	Hex Size	Overall Length	Shank Length
1823-1	1/4" NPTF	7/8"	1-1/4"	1/2"
1822-A1	3/8" NPTF	7/8"	1-5/16"	9/16"
1820-1	1/2" NPTF	7/8"	1-1/16"	1/2"

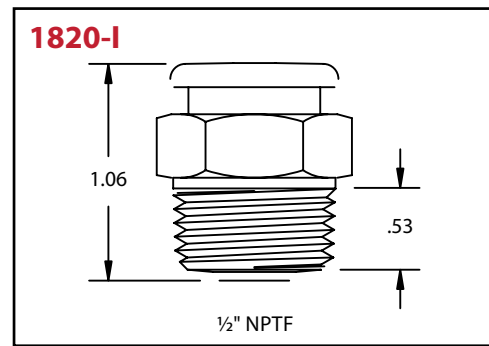
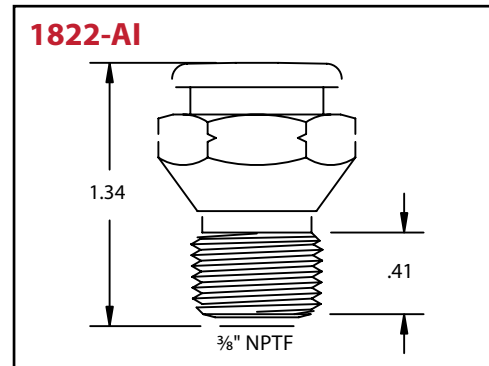
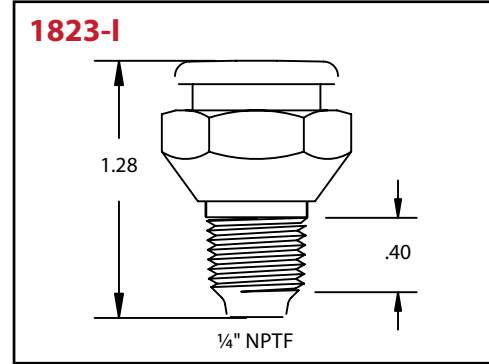

# INDUSTRIAL LUBRICATION FITTINGS

## RELIEF FITTINGS

Alemite Relief Fittings are used on gearbox housings and bearings (king pins, universal joints, etc.) where excessive lubrication pressure is not desired.

FEATURES:

- Exceeds 72 hour salt spray test
- Trivalent zinc plating
- RoHS compliant
- Fittings open at predetermined pressure (see table)
- May be used with grease or oil
- 338382 is a leak proof fitting

RECOMMENDED ACCESSORIES

- 1/8" – 1/4" Bushing (45120)

## British Standard Pipe Thread Fittings

FEATURES:

- Dirt excluding check ball
- Trivalent zinc plating
- RoHS compliant

Product #	Description	Opening Pressure
317400-E	1/8" BSPT Relief Fitting	1/4 to 1 psi
47200-E	1/8" BSPT Relief Fitting	1 to 5 psi
47100-E	1/8" BSPT Relief Fitting	45 to 80 psi

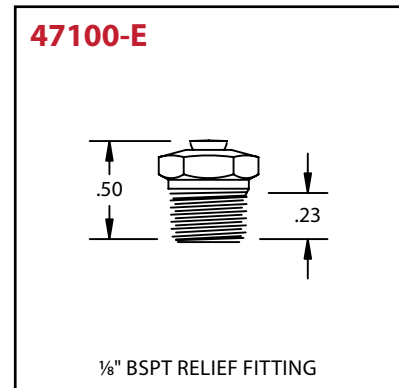



## RELIEF FITTINGS

### 1/8" Pipe Thread

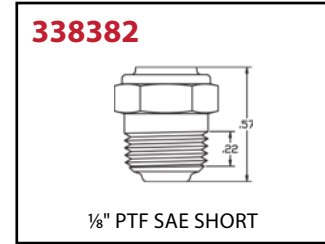
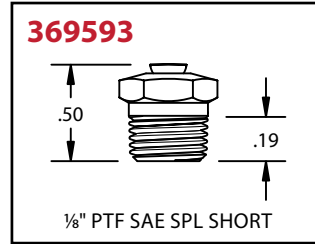
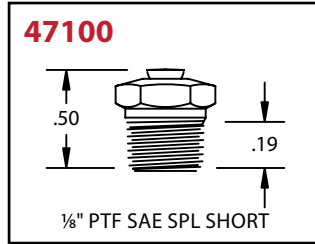

Product #	Thread	Relief Pressure		Pressure Based on Using Air/Grease/Oil
		Min	Max	
317400	1/8" PTF SAE SPL Short	.25 psi	1 psi	Air at 1.2 Ft3/Hr
47200	1/8" PTF SAE SPL Short	1 psi	5 psi	Oil 30W SAE
47640	1/8" PTF SAE SPL Short	7.5 psi	15 psi	Oil 30W SAE
323060	1/8" PTF SAE SPL Short	15 psi	25 psi	Oil 30W SAE
47100	1/8" PTF SAE SPL Short	45 psi	80 psi	Oil 30W SAE
50500	1/8" PTF SAE SPL Short	400 psi	650 psi	NLGI 1 Grease, Calcium Based
369593	1/8" PTF SAE SPL Short	100 psi	200 psi	NLGI 1 Grease, Calcium Based
338382	1/8" PTF SAE SPL Short	80 psi	140 psi	Oil 30W SAE

### Drive

Product #	Drive Fitting	Relief Pressure	
		Min	Max
321839	3/8" Diameter Drill	1 psi	5 psi

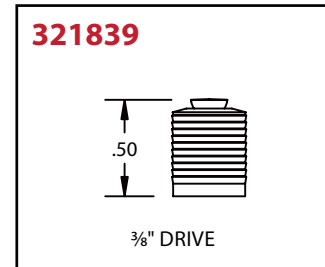



# INDUSTRIAL LUBRICATION FITTINGS

## FLUSH TYPE FITTINGS

Alemite Flush Type Fittings are used where protruding fittings are not desirable, such as for line shafting pulleys or revolving bearings.

### FEATURES:

- Exceeds 72 hour salt spray test
- Dirt excluding check ball
- Trivalent zinc plating
- RoHS compliant
- Flush mounting reduces potential for damage

## Threaded - Slotted

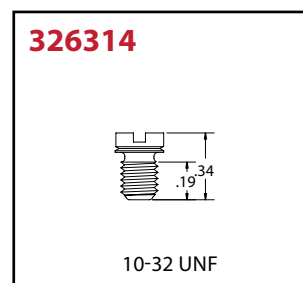
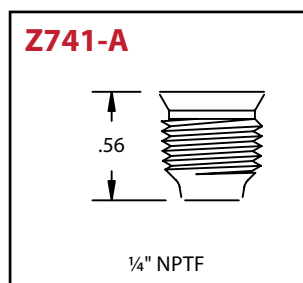
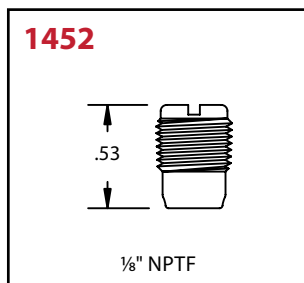
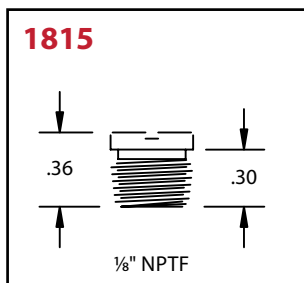

Product #	Thread	Type	Overall Length	Shank Length	Drill Diameter
1815	Overall Length	Slotted	Shank Length	19/64"	—
1452	Overall Length	Slotted	Shank Length	—	—
Z741-A	Overall Length	Slotted	Shank Length	—	—
326314	10-32 UNF	Slotted	3/8"	15/64"	—



## FLUSH TYPE FITTINGS

### Threaded - Hex

Product #	Thread	Type	Overall Length	Shank Length	Drill Diameter
1851	1/4"-28 NF	Hex	13/32"	19/64"	—

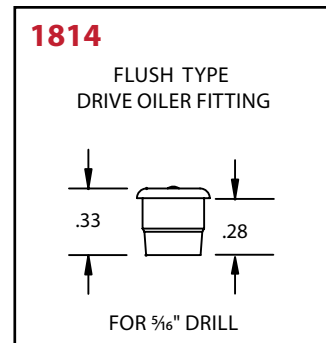
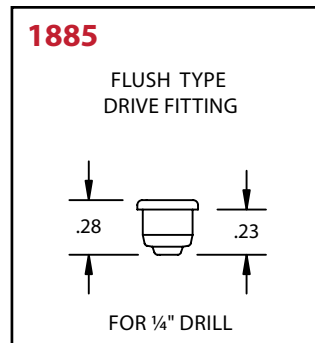
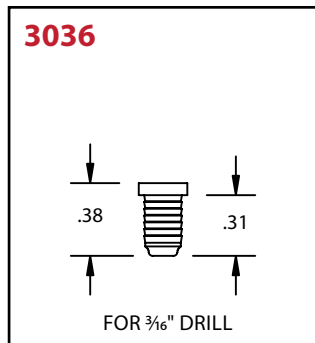
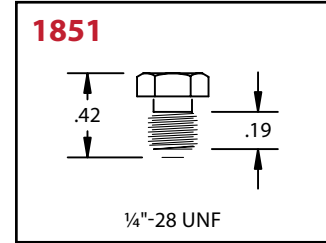

### Drive

Product #	Thread	Type	Overall Length	Shank Length	Drill Diameter
3036	Drive	Straight	3/8"	5/16"	3/16"
1885	Drive	Straight	9/32"	15/64"	1/4"
1814	Drive	Straight	21/64"	9/32"	5/16"

# INDUSTRIAL LUBRICATION FITTINGS

## LEAKPROOF FITTINGS

To improve reliability of the check valve in these fittings, keep input passages free of foreign particles. Redundancy of seal should be provided in critical applications where back pressure must be maintained.

### Threaded

RECOMMENDED ACCESSORY:

- Dust Caps

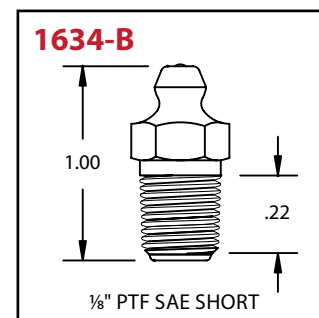
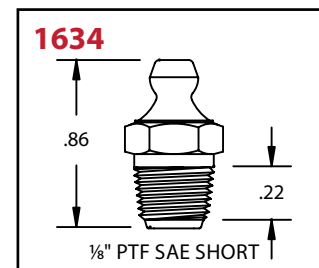
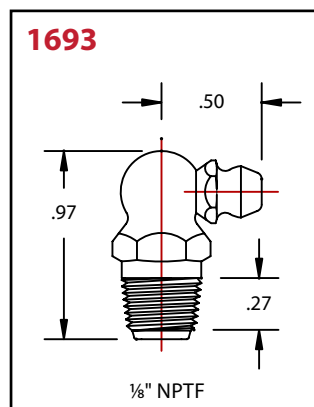
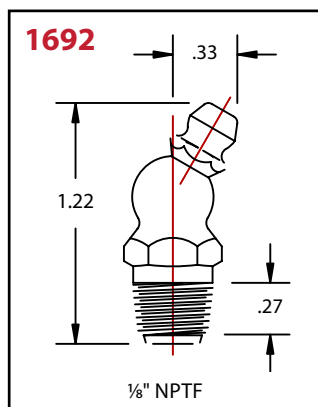
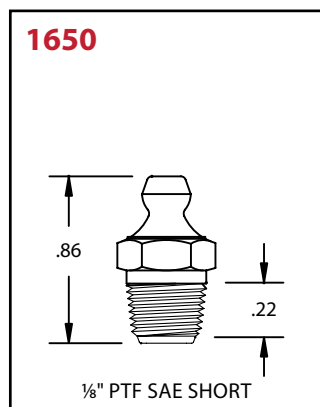

Product #	Type	Thread	Hex Size	Overall Length	Shank Length	Check Valve	Max. Back Pressure
1650 <sup>(1)</sup>	Straight	1/8" PTF SAE Short	7/16"	29/32"	25/64"	Fluoroelastomerer Ball	3,000 psi
1692 <sup>(1)</sup>	30°	1/8" NPTF	7/16"	1-7/32"	25/64"	Buna-N disk	3,000 psi
1693 <sup>(1)</sup>	90°	1/8" NPTF	7/16"	31/32"	25/64"	Buna-N disk	3,000 psi
1634 <sup>(2)</sup>	Straight	1/8" PTF SAE Short	7/16"	27/32"	23/64"	Steel Ball/Brass Seat	10,000 psi
1634-B <sup>(2)</sup>	Straight	1/8" PTF SAE Short	7/16"	1"	33/64"	Steel Ball/Brass Seat plus dirt excluding surface ball check	10,000 psi

<sup>(1)</sup> Designed for light oils

<sup>(2)</sup> Designed for grease, medium and heavy oils

### Drive

Product #	Type	Thread	Press Fit OD	Overall Length	Check Valve	Max Back Pressure
369533	Straight	—	7/16"	55/64"	Steel Ball/Brass Seat	*

\* Maximum pressure depends on the press fit

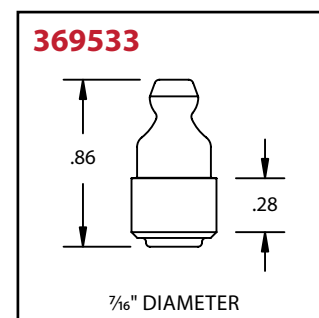



## VENTS

### Vents

Alemite Vents are used with transmissions, speed reducers, axles, gear housings and similar applications. The vent is placed above normal lubrication level to allow air to escape when internal pressure rises.

**FEATURES:**

- Exceeds 72 hour salt spray test
- Trivalent zinc plating
- Vent opens at designated pressure (see table)
- Helps to prevent fluid leakage
- Special cap prevents water or dirt from entering

Product #	Thread	Opening Pressure
300805	1/8" PTF SAE Short	Felt filter
304810	1/8" PTF SAE Short	1-3" water
324970	Drive 3/8". Designed as 0.374 ±0.000-0.003 drive. Use 0.368" drill or U drill.	6-12" water, 0.25 to 0.43 psi
131000-T	1/8" PTF SAE Short	12" water max
327240	1/8" PTF SAE Short	1 to 1-1/2 psi
330766	1/8" PTF SAE Short	2-1/2 to 4 psi
369622	1/8" PTF SAE Special Short	2-1/2 to 4 psi
369602	1/8" PTF SAE Short	1 to 2 psi

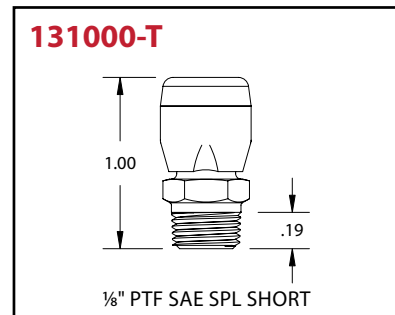
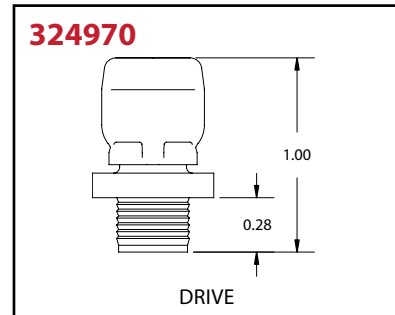
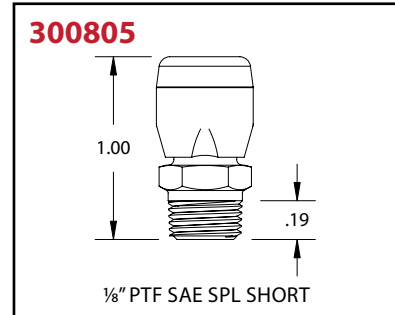

## BREATHERS

### Breathers

Alemite Breathers are used with transmissions, differentials, speed reducers, axles, gear housings and similar applications. The breather helps maintain proper pressure.

**FEATURES:**

- Exceeds 72 hour salt spray test
- Trivalent zinc plating
- No airflow restrictions
- Breathers with felt filters help reduce dirt contamination

Product #	Description	Thread
313650	Two Baffles	3/8" PTF SAE Short
369583 <sup>(1)</sup>	Corrosion Resistant	1/8" PTF SAE Short
369528	Press Fit, Two Baffles	Goes into .497/.5032 DIA hole
321620	Zinc Trivalent	1/8" PTF SAE SPL Short
369518	Double Vent	Drive 0.374±0.000-0.003 hole Use 0.36" drill or U drill
369568	M 10 x 1.5	M 10 x 1.5

<sup>(1)</sup> 240 hour salt spray test

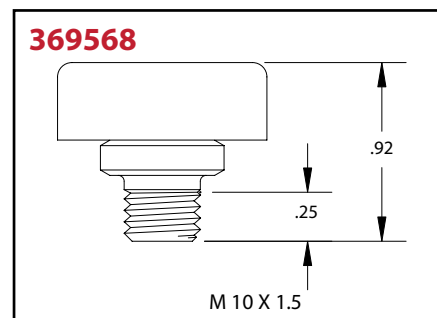
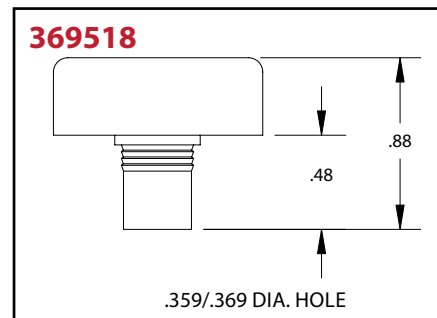
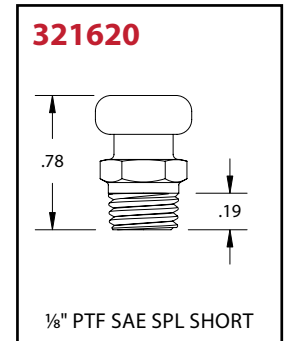
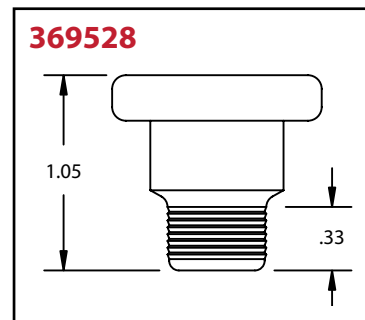
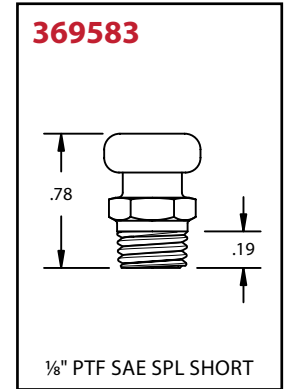
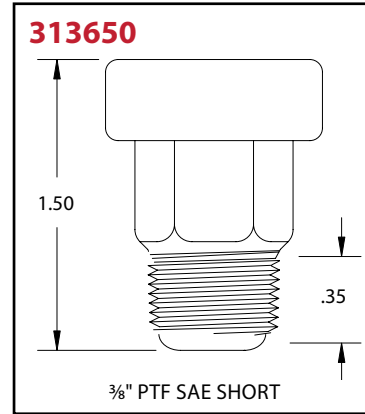



## SPECIALTY FITTINGS

### Special Thread Fittings

Alemite offers special threads and sizes for special lubrication applications. All have high pressure ball check unless noted.

**FEATURES:**

- Exceeds 72 hour salt spray test
- Dirt excluding check ball
- Trivalent clear zinc plating
- RoHS compliant
- 3016, 3018 and 369616 have no ball check

Product #	Thread	Type	Hex Size	Overall Length	Shank Length
3016	10-32 UNF-2A	Straight	1/4"	1/2"	1/8"
3018	6-40 UNF-2A	Straight	1/4"	1/2"	9/64"
1711-B	5/16"-24 UNF-2A	Straight	3/8"	21/32"	5/32"
1631-B	5/16"-32 UNEF-2A	Straight	3/8"	21/32"	15/64"
1648-B1	5/16"-32 UNEF-2A	65°	3/8"	51/64"	7/32"
369616	10-32 UNF-2A	Straight	1/4"	15/32"	5/64"

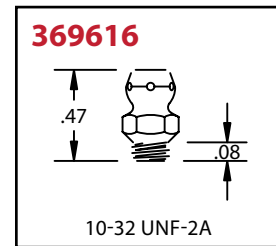
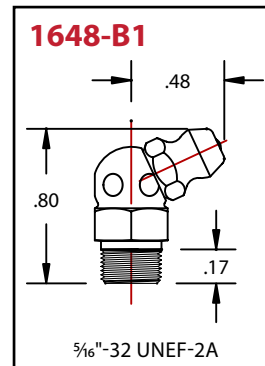
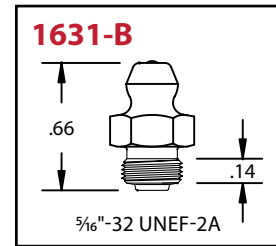
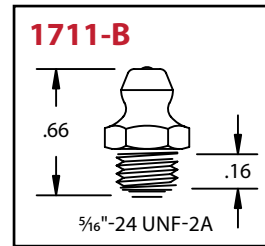
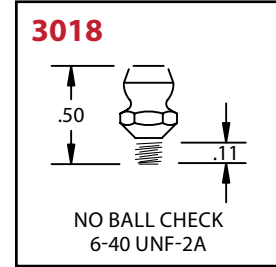
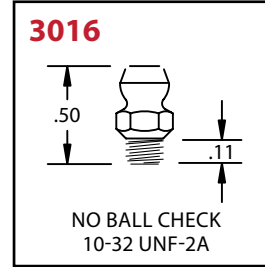

## SPECIALTY FITTINGS

### Rivet Fittings

Alemite Rivet Fittings are used where threaded or drive fittings are difficult to use. They are commonly used for king pin applications.

#### FEATURES:

- Exceeds 72 hour salt spray test
- Dirt excluding check ball
- Trivalent zinc plating
- RoHS compliant

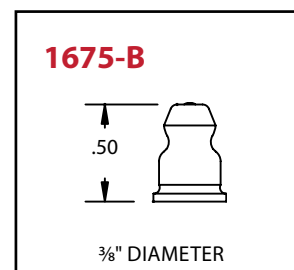

Product #	Type	Overall Length	Fitting Diameter	Rivet Diameter
1675-B	Straight	1/2"	3/8"	5/16"

### Pin Type Fittings

Alemite Pin Type Fittings have positive locking action on coupler and cross pin, providing a leakproof connection.

#### FEATURES:

- Exceeds 72 hour salt spray test
- Dirt excluding check ball
- Trivalent zinc plating
- RoHS compliant

#### RECOMMENDED ACCESSORIES:

- Pin Type Couplers (VB942, 50491, 51185)

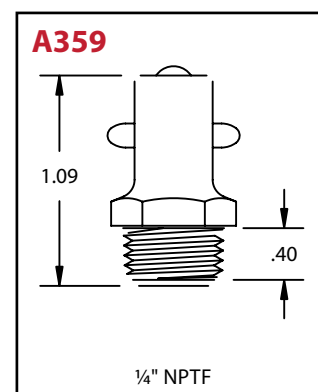
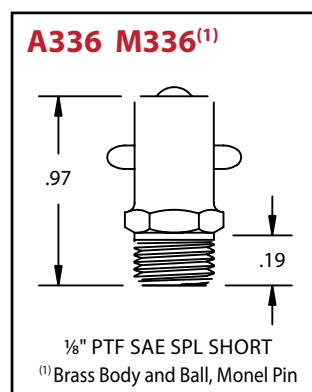

Product #	Thread	Type	Hex Size	Overall Length	Shank Length
A336	1/8" PTF	Straight	7/16"	31/32"	17/64"
A359	1/4" NPTF	Straight	17/32"	1-3/32"	5/16"
M336	1/8" PTF	Straight	7/16"	31/32"	17/64"

## SPECIALTY FITTINGS

### Hydraulic Shut Off Fittings

Alemite Hydraulic Shut Off Fittings positively shut off at specified pressure, preventing over-lubrication and damaging of bearing seals.

**FEATURES:**

- Exceeds 72 hours salt spray test
- Dirt excluding check ball
- Trivalent zinc plating
- RoHs compliant

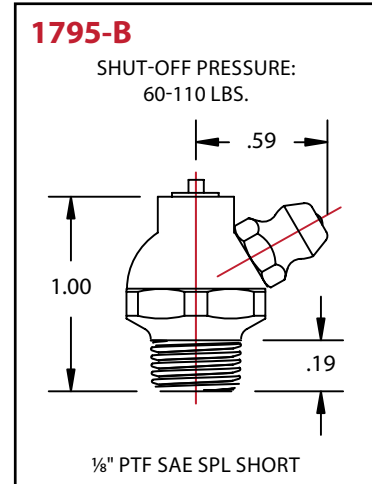
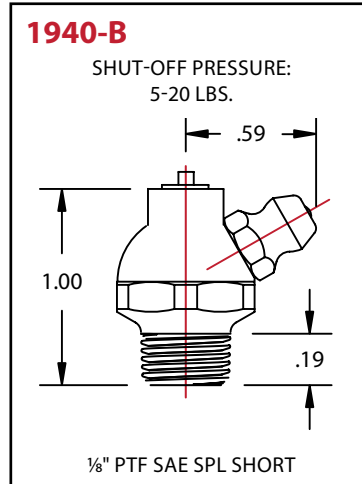

Product #	Type	Hex Size	Overall Length	Shank Length	Shut-off Pressure
1940-B	60°	5/8"	1"	17/64"	5-20 psi
1795-B	60°	5/8"	1"	17/64"	60-110 psi

### Bullet Nose Fitting

Product #	Thread	Type	Hex Size	Overall Length
369613	1/4"-28 SAE-LT	Straight	0.28"	0.51"

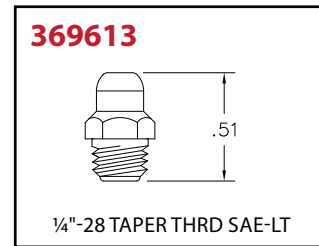





# INDUSTRIAL LUBRICATION FITTINGS

## FITTING ASSORTMENTS

### Blister Packs

Alemite Blister Packs are packaged for display or easy storage. Each pack contains 10 fittings unless otherwise noted.

Product #	Type	Hex Size	Overall Length	Shank Length	Quantity
B1610-BL	Straight	7/16"	11/16"	19/64"	10
B1611-B	30°	7/16"	29/32"	19/64"	10
B1613-B	90°	7/16"	27/32"	19/64"	10
B1627-B	Straight	9/16"	7/8"	27/64"	5
B1629-B	67.5°	9/16"	31/32"	11/32"	5
B1637-B1	45°	3/8"	13/16"	13/64"	10
B1641-B	Straight	5/16"	35/64"	3/16"	10
B1688-B	45°	7/16"	57/64"	19/64"	10
B1911-B1	90°	3/8"	3/4"	13/64"	10
B2103	Straight	9 mm	5/8"	1/4"	10
B2105	90°	10 mm	3/4"	7/32"	10
B2106	Straight	7 mm	19/32"	1/4"	10
B2108	90°	10 mm	3/4"	7/32"	10
B2109	Straight	11 mm	5/8"	1/4"	10



## FITTING ASSORTMENTS

### Multiple Size Assortments -Standard

Alemite Standard Fitting Assortments include a selection of popular standard sized fittings.

FEATURES:

- All Purpose Fitting Assortment (2364-1) includes 2 tools for extracting fittings and rethreading holes
  - B315790 – 1/4"-28 Fitting Tool
  - B315791 – 1/8" PTF Fitting Tool



**2364-1**



**2365-1**

Product #	Description	1610-BL	1688-B	1613-B	1641-B	1637-B1	1911-B1	1611-B	1612-B
2398-1	Vehicle Fitting Assortment	24	12	12	24	12	12	–	–
2364-1	All Purpose Fitting Assortment	36	12	12	24	12	12	12	12
2365-1	Pocket Pack Fitting Assortment	12	6	6	12	6	6	–	–

### Multiple Size Assortments - Metric

Alemite Metric Fitting Assortments include a selection of metric fittings.



**2371**

Product #	Description	2106	2107	2108	2103	2105	2109
2371	Metric Fitting Assortment	10	6	6	6	6	10

## FITTING ACCESSORIES

### Header Blocks

Alemite Header Blocks allow hard to reach lubrication points to be connected to fittings by tubing or whip hose.

#### FEATURES:

- Available with or without fittings
- Configured to serve 3 or 6 lubrication points
- Includes compression fittings for 1/4" tubing



Product #	Size	Length	Inlet/Outlet Threads	Fittings
6135	3-point	2-3/4"	1/8" NPTF(f)	1612-B
6136	6-point	5-3/4"	1/8" NPTF(f)	1612-B
42702 <sup>(1)</sup>	3-point	2-3/4"	1/8" NPTF(f)	—
42703 <sup>(1)</sup>	6-point	5-3/4"	1/8" NPTF(f)	—

<sup>(1)</sup> Header block only, fittings not included.

### Plastic Caps

Plastic Caps protect fittings from corrosion and debris, and are available in red or white color.

Product #	Color	Quantity per Box
339630-RD	Red	100
339630-WH	White	100

### 45° Adapters

Alemite Adapters are used to adapt a threaded fitting to a different size opening thread.

Product #	Thread	Type	Thread (female)
310912	1/4"-28 Taper Thread (SAE-LT)(m)	45°	1/8" NPTF(f)

### Tubing & Connectors

Use Alemite tubing and connectors to ensure proper fit and connections when installing remote lube points.



Product #	Description
339760	Push to lock tube fitting
339762-50	1/4" Nylon tubing 50 ft
339762-150	1/4" Nylon tubing 150 ft
339738	1/4" Steel tube fitting 1/8" NPT
339813	1/4" Steel tube fitting 1/4" NPT

### Compression Tube Fitting

Product #	Size	Inlet/Outlet Thread
328303-42	1/4" tube fitting	1/8" NPTF(f)

## FITTING ACCESSORIES

## Fitting Extensions

Alemite Fitting Extensions are used to extend fittings away from a bearing housing.

Product #	Thread	Hex Size	Effective Thread Length	Overall Length	Shank Length
43761	1/8" NPTF(f) x 1/8" NPTF(m)	1/2"	3/16"	3/4"	9/32"
43762	1/8" NPTF(f) x 1/8" NPTF(m)	1/2"	17/64"	1-1/4"	11/16"
336551	1/4"-28 Taper Thread (SAE-LT)(m) x 1/4"-28 UNF-3B(f)	—	13/64"	1-1/4"	1"



43762

## Straight Adapters

Product #	Thread	Thread (M / F)	Type
327033	1/4" NPTF(m)	1/4" NPTF(m)	Straight
130552	1/4" NPTF(m)	1/2" NPTF(m)	Straight
43379	1/4" NPTF(m)	1/2"-27 Taper(m)	Straight
41729	3/8" NPTF(m)	3/8" NPTF(m)	Straight
47703	7/16"-27 UNS-2A (m)	1/2"-27 NS Taper(m)	Straight
44734	3/8" NPTF(m)	1/2"-27 Taper(m)	Straight
51888	1/2" NPTF(m)	1/2" NPTF(m)	Straight
307925	1/2" NPTF(m)	1/2"-27 NS Taper(m)	Straight
42159	1/2"-27 NS Taper(m)	1/2"-27 NS Taper(m)	Straight
43760	1/8" NPTF(m)	1/4" NPTF(f)	Straight
52797	3/8" NPTF(m)	1/2" NPTF(f)	Straight
305859	7/16"-27 UNS-2A (m)	1/8" NPTF(f)	Straight
51942	1/4"-28 Taper Thread (SAE-LT)(m)	1/8" NPTF(f)	Straight
1000-44	1/4" NPTF(m)	1/4" NPSM(f)	Straight, Swivel
1000-88	1/2" NPTF(m)	1/2" NPSM(f)	Straight, Swivel
1012-88	1/2" NPTF(f)	1/2" NPSM(f)	Straight, Swivel



305859



43760

## FITTING ACCESSORIES

### 90° Adapters

Alemite Adapters are used to adapt a threaded fitting to a different size opening thread.

Product #	Thread	Type	Thread (female)
51943	1/4"-28 Taper Thread (SAE-LT)(m)	90°	1/8" NPTF(f)
1001-44	1/4" NPTF(m)	90°, Swivel	1/4" NPSM(f)
1001-66	3/8" NPTF(m) x 3/8" NPTF(f)	90°, Swivel	3/8" NPSM(f)
1001-86	1/2" NPTF(m) x 3/8" NPTF(f)	90°, Swivel	3/8" NPSM(f)
1001-88	1/2" NPTF(m) x 1/2" NPTF(f)	90°, Swivel	1/2" NPSM(f)



**1001-88**

### Plugs

Alemite Plugs close openings where a fitting is no longer required.

Product #	Description
1480	1/8" NPTF Square Head
17831	1/8" NPTF Hex Socket
170008	1/4" NPTF Hex Socket
328224	1/4"-28 Taper Thd (SAE-LT) Hex Head
328435	1/4"-28 Taper Thd (SAE-LT) Thread Forming Hex Head



**328435**

### Bushings

Alemite Bushings are zinc plated to resist corrosion.

Product #	Thread (male)	Thread (female)
45120	1/4" NPTF	1/8" NPTF
A112	3/8" NPTF	1/8" NPSI
40996	3/8" NPTF	1/4" NPTF
A113	1/2" NPTF	1/8" NPSI
51891	1/2" NPTF	1/4" NPTF
131586	1/2" NPTF	3/8" NPTF
320354	1" NPTF	1/2" NPTF
338552	2" NPT	3/4" NPT



**45120**

## FITTING ACCESSORIES

## Couplers - Hydraulic

Alemite Hydraulic Couplers provide quick, positive and leakproof connection with hydraulic fittings.

Product #	Thread	Type	Length	Pressure	Other Features
6304-B	1/8" NPTF(f)	Standard	–	10,000 psi (690 bar)	Metal Seal
6304-C	1/8" NPTF(f)	Standard	–	10,000 psi (690 bar)	Metal Seal; built-in check valve
308730	1/8" NPTF(f)	Narrow	–	10,000 psi (690 bar)	Rubber Seal
308730-A	1/8" NPTF(f)	Narrow	–	10,000 psi (690 bar)	Rubber Seal; built-in check valve
B330070	1/8" NPTF(f)	Narrow	–	10,000 psi (690 bar)	Metal Seal; blister packed
B154	1/8" NPTF(f)	Narrow	–	10,000 psi (690 bar)	Rubber Seal & 4 Jaw design
322120	1/8" NPTF(f)	Narrow	–	10,000 psi (690 bar)	Rubber Seal; 90°
6509-D	1/8" NPTF(f)	Standard 360° Swivel	3-1/2"	10,000 psi (690 bar)	Metal Seal
6509-E	1/8" NPTF(f)	Narrow 360° Swivel	4"	10,000 psi (690 bar)	Rubber Seal



6304-B



6509-D

## Couplers - Button Head

Product #	Thread	Type	Pressure	Other Features
42030	7/16"-27 NS-2(f)	Standard Pull-On	10,000 psi (690 bar)	–
42030-A	1/8" NPTF(f)	Standard Pull-On	10,000 psi (690 bar)	7/16 - 27 x 1/8" NPT(f) Threaded adapter (305859); Gasket (50679)
42031-A	1/8" NPTF(f)	Standard Push-On	10,000 psi (690 bar)	7/16 - 27(m) x 1/8" NPT(f) Threaded adapter (305859); Gasket (50679)
304300	7/16"-27 NS-2(f)	Giant Pull-On	15,000 psi (1,030 bar)	–
304300-A	1/8" NPTF(f)	Giant Pull-On	15,000 psi (1,030 bar)	7/16 - 27 x 1/8" NPT(f) Threaded adapter (305859)
319702	1/4" PTF SAE Short(f)	Giant Pull-On	15,000 psi (1,030 bar)	–
304301	7/16"-27 NS-2(f)	Giant Push-On	15,000 psi (1,030 bar)	–



42030

## Couplers - Pin Type

Product #	Thread	Type	Pressure
VB942	1/8" NPTF(f) without wing	Pin	10,000 psi (690 bar)
50491	1/8" NPTF(m) with wing	Pin	10,000 psi (690 bar)
51185	1/8" NPTF(f) with wing	Pin	10,000 psi (690 bar)



50491

## FITTING ACCESSORIES

### Couplers - Flush Type Nozzle

Product #	Thread	Type	Pressure
314150	1/8" NPTF(f)	Midget	10,000 psi (690 bar)
Z737	1/8" NPTF(f)	Standard	10,000 psi (690 bar)

### Couplers - Kits

Product #	Description
398727	Standard Button Head Coupler Kit
398726	Giant Button Head Coupler Kit

### Fitting Tools

Zerk-Mate fitting cleaning tools are a quick, effective way to unplug clogged grease fittings. Light viscosity oil is injected into the plugged joint, loosening grease and allowing new grease to enter, saving the time of replacing fittings and joints. Available in standard and pocket sized models. Easy out fitting tools are used to extract broken fittings, rethread holes, and install new fittings.

Product #	Description	Thread	Weight
339841	Heavy-Duty Zerk-Mate to unclog fittings	–	1.5 lb (680 g)
340004	Pocket-Sized Joint/Fitting Cleaner	–	8 oz (226 g)
B315790	Easy-out fitting tool to remove and install fittings	1/4"-28 Taper Thread	0.2 lb (90 g)
B315791	Easy-out fitting tool to remove and install fittings	1/8" NPTF	0.2 lb (90 g)



### Elbow Bodies

Alemite Elbow Bodies change the angle of a fitting to be attached to a bearing.

Product #	Thread	Angle	Overall Length	Shank Length	Thread Length
43706	1/8" NPTF(f) x 1/8" PTF SAE Short(m)	90°	1-1/8"	17/32"	17/64"
43716	1/8" NPTF(f) x 1/8" PTF SAE Short(m)	45°	1"	7/16"	7/32"
44701	1/8" NPTF(f) x 1/8" PTF SAE Short(m)	90°	1"	7/16"	7/32"
43718	1/8" NPTF(f) x 1/4" PTF(m)	90°	1-3/16"	5/8"	13/32"
43748	1/4" NPTF(f) x 1/4" PTF(m)	90°	1-11/32"	19/32"	13/32"
369586	1/4"-28 Taper Thread SAE-LT(f) x 1/4"-28 UNF-2B(m)	65°	45/64"	1/5"	19/64"
369594	1/4"-28 Taper Thread SAE-LT(f) x 1/4"-28(m)	45°	45/64"	1/5"	19/64"
306722	1/8" NPTF(m) x 1/4" NPTF(m) adapter	Straight	1-3/16"	1/4" end -37/64" 1/8" end -25/64"	1/4" end -13/32" 1/8" end -17/64"
51943	1/4"-28(m) Taper x 1/8" NPTF(f)	90°	1.03"	0.22"	0.110" (minimum)







# AEROSPACE FITTINGS



- ▶ Steel Fittings
- ▶ Monel
- ▶ Stainless Steel

Aerospace and military applications require absolute reliability, durability and performance. Alemite AS Fittings meet the very stringent requirements of SAE AS 35411 standards, including complete documentation and traceability certified from raw materials through production.

## STEEL FITTINGS

Alemite Aerospace (AS) Fittings are designed specifically to meet requirements for performance and consistency which are imperative in aircraft and other critical use applications. Alemite AS Fittings meet the stringent requirements of SAE AS 35411, which include performance tests, extensive documentation and complete traceability of materials. The AS 35411 specification supersedes previous Military Specification MIL-F-3541. Look for the Alemite "AS Fitting Notch" on the neck of the fitting.

## Zinc Finish



AS Part #	Alemite Part #	Supersedes MS #	NSN #	Material	Finish	Type	Thread	Boeing Part #	NAS Part#
AS15001-1P	1641-AS	MS-15001-1	4730000504203	Steel	Zinc	Straight	1/4"-28 Taper (SAE-LT)	-	-
AS15001-2P	1680-AS	MS-15001-2	4730001720001	Steel	Zinc	Straight, .97" long	1/4"-28 Taper (SAE-LT)	-	-
AS15001-3P	1637-AS	MS-15001-3	4730000504205	Steel	Zinc	45°	1/4"-28 Taper (SAE-LT)	-	-
AS15001-4P	1911-AS	MS-15001-4	4730000504207	Steel	Zinc	90°	1/4"-28 Taper (SAE-LT)	-	-
AS15002-1P	1792-AS	MS-15002-1	4730001720010	Steel	Zinc	Straight	1/4"-28 Taper UNF-2A	-	-
AS15002-3P	1770-AS	MS-15002-3	4730001720015	Steel	Zinc	45°	1/4"-28 Taper UNF-2A	-	-
AS15003-1P	1610-AS	MS-15003-1	4730000504208	Steel	Zinc	Straight, .69" long	1/8"-PTF-SAE Special Short	-	-
AS15003-2P	1607-AS	MS-15003-2	4730001720022	Steel	Zinc	Straight, 1.25" long	1/8"-PTF-SAE Special Short	-	-
AS15003-3P	1611-AS	MS-15003-3	4730001720025	Steel	Zinc	30°	1/8"-PTF-SAE Special Short	-	-
AS15003-4P	1688-AS	MS-15003-4	4730001720028	Steel	Zinc	45°	1/8"-PTF-SAE Special Short	-	-
AS15003-5P	1612-AS	MS-15003-5	4730001720031	Steel	Zinc	65°	1/8"-PTF-SAE Special Short	-	-
AS15003-6P	1613-AS	MS-15003-6	4730001720034	Steel	Zinc	90°	1/8"-PTF-SAE Special Short	-	-
AS15006-1P	1650-AS	MS-15006-1	4730001730049	Steel	Zinc	Straight Leak Proof	1/8"-PTF-SAE Short	-	-
AS15006-2P	1692-AS	MS-15006-2	4730001730052	Steel	Zinc	30° Leak Proof	1/8"-NPTF	-	-
AS15006-4P	1693-AS	MS-15006-4	4730001730058	Steel	Zinc	90° Leak Proof	1/8"-NPTF	-	-



# AEROSPACE FITTINGS

## STEEL FITTINGS

### Zinc Nickel Finish

AS Part #	Alemite Part #	Supersedes MS #	NSN #	Material	Finish	Type	Thread	Boeing Part #	NAS Part#
AS15001-1U	1641-AS1	–	–	Steel	Zinc Nickel	Straight	1/4"-28 Taper (SAE-LT)	BACF19F-1LZ	–
–	1984-AS1	–	–	Steel	Zinc Nickel	Straight	1/4"-28 Taper (SAE-LT)	BACF19F-1Z	–
AS15001-2U	1680-AS1	–	–	Steel	Zinc Nickel	Straight, .97" long	1/4"-28 Taper (SAE-LT)	BACF19F-2LZ/2Z	–
AS15001-3U	1637-AS1	–	–	Steel	Zinc Nickel	45°	1/4"-SAE-LT Taper	BACF19F-3LZ/3Z	–
AS15001-4U	1911-AS1	–	–	Steel	Zinc Nickel	90°	28 Taper (SAE-LT)	BACF19F-4LZ BACF19F-4Z	–
AS15002-1U	1792-ASI	–	–	Steel	Zinc Nickel	Straight	1/4"-28 (UNF-2A)	–	–

## MONEL

## Bright Dipped

AS Part #	Alemite Part #	Supersedes MS #	NSN #	Material	Finish	Type	Thread	Boeing Part #	NAS Part#
AS15004-1	1966-AS3	MS-15004-1	4730001720040	Monel	Bright Dip	Straight	1/4"-28 Taper (SAE-LT)	BACF19G-1L	–
AS15004-2	1968-AS3	MS-15004-2	4730001720041	Monel	Bright Dip	45°	1/4"-28 Taper (SAE-LT)	BACF19G-2L & BACF19G-2	–
AS15004-3	1969-AS3	MS-15004-3	4730001720042	Monel	Bright Dip	90°	1/4"-28 Taper (SAE-LT)	BACF19G-3L & BACF19G-3	–
AS15005-1	1961-AS3	MS-15005-1	4730001720043	Monel	Bright Dip	Straight	1/8"-PTF-SAE Special Extra Short	–	–
AS15005-3	1921-AS3	MS-15005-3	4730001720045	Monel	Bright Dip	30°	1/8"-PTF-SAE Special Short	–	–
AS15005-4	1922-AS3	MS-15005-4	4730001720046	Monel	Bright Dip	65°	1/8"-PTF-SAE Special Short	–	–
AS15005-5	1923-AS3	MS-15005-5	4730001720047	Monel	Bright Dip	90°	1/8"-PTF-SAE Special Short	–	–



# AEROSPACE FITTINGS

## STAINLESS STEEL

### Passivated Finish

AS Part #	Alemite Part #	Supersedes MS #	NSN #	Material	Finish	Type	Thread	Boeing Part #	NAS Part#
AS15720-1	1966-AS2	MS-15720-1	–	303 SS	Passivated	Straight	1/4"-28 Taper (SAE-LT)	–	–
AS15720-2	1968-AS2	MS-15720-2	–	304 SS	Passivated	45°	1/4"-28 Taper (SAE-LT)	–	–
AS15720-3	1969-AS2	MS-15720-3	–	305 SS	Passivated	90°	1/4"-28 Taper (SAE-LT)	–	–
AS15721-1	1961-AS2	MS-15721-1	4730009725789	306 SS	Passivated	Straight	1/8"-PTF-SAE Special Extra Short	–	–
AS15721-3	1921-AS2	MS-15721-3	–	307 SS	Passivated	30°	1/8"-PTF-SAE Special Short	–	–
AS15721-4	1922-AS2	MS-15721-4	–	308 SS	Passivated	65°	1/8"-PTF-SAE Special Short	–	–
AS15721-5	1923-AS2	MS-15721-5	4730002013243	309 SS	Passivated	90°	1/8"-PTF-SAE Special Short	–	–

