

**WPT POWER**  
CORPORATION

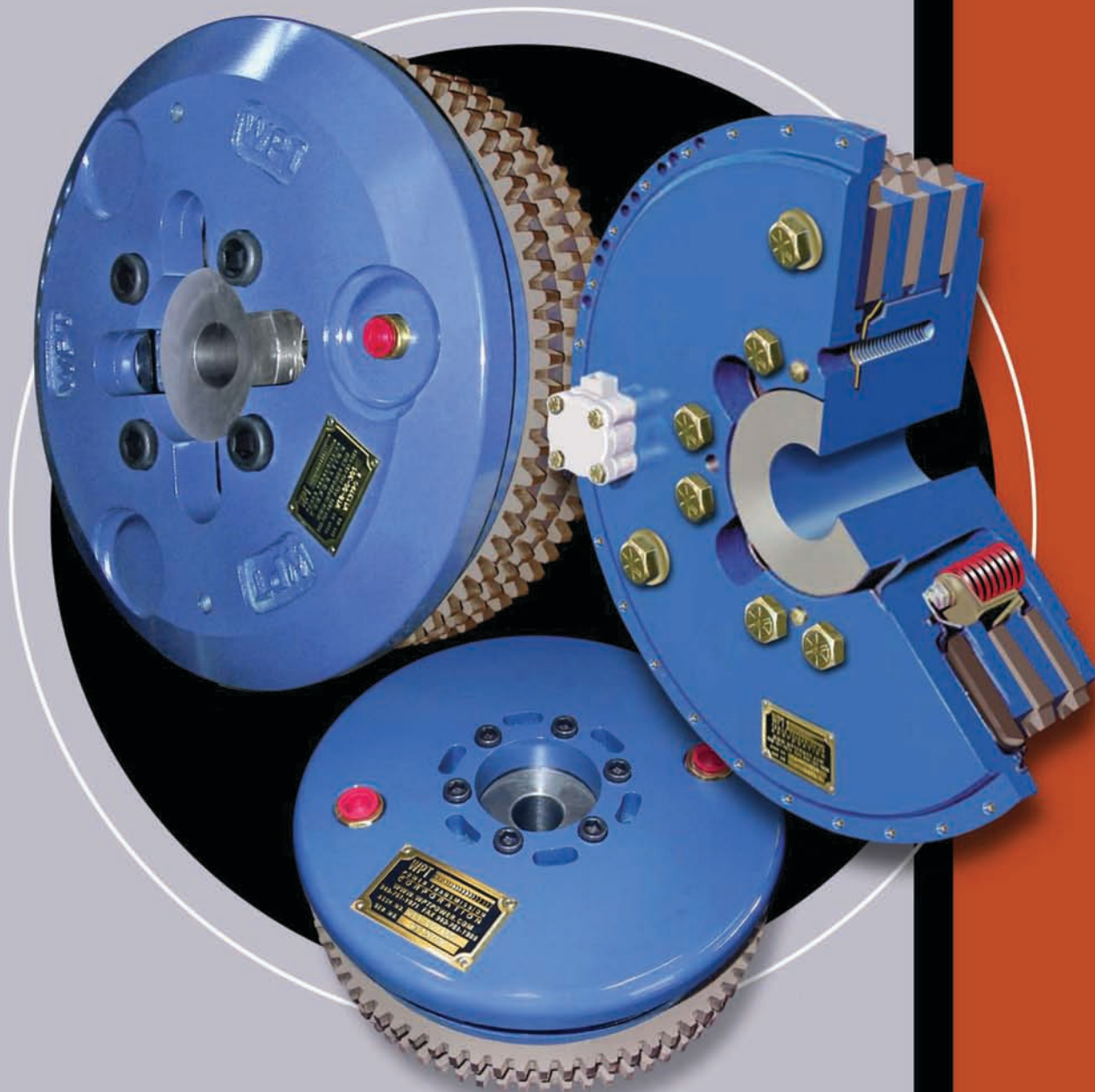

## Power Grip & Power Grip PO Clutches



# New Wave Spring Replaces Coil Spring

WPT has incorporated a major design improvement into the Power Grip Clutch.



The wave spring is designed to replace coil springs in new and existing clutches. Only one wave spring per plate is

required versus several coil springs. The wave spring allows simple assembly of a clutch on the shaft without the use of special tools used to retain the obsolete coil springs. When used with the “extended teeth” hubs maintenance time is dramatically reduced.

New Power Grip Clutch with Wave Springs

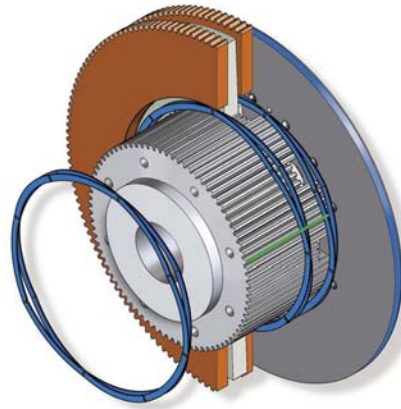

Power Grip Clutch with Coil Springs

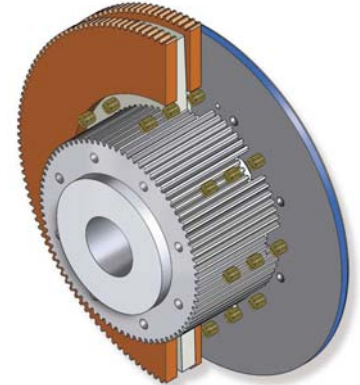

Maximum Speed of Clutch Utilizing Wave Springs

Clutch Size	Max rpm with Wave Springs
14" / 14H	1430
16"	1300
18" / 18H	1180
21"	1110
24" / 24H / 24SHD	940
27"	900
30" / 30H	860
36"	600

The wave spring is designed to replace coil springs in older WPT Power Grip Clutches.

# Extended Teeth Makes Re-Assembly Easier

WPT's patented extended tooth hub for Power Grip Clutches greatly assists in re-assembly of the clutch while mounted on a shaft. The extended teeth allow for all center/ floating plates to remain engaged on the hub teeth with the release springs in a relaxed state. Previous designs required special clamps to retain all parts on the hub until the airtube holding plate could be installed and the bolts installed.

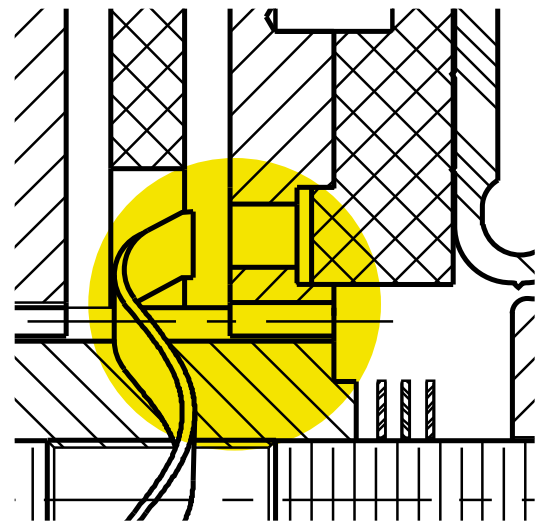
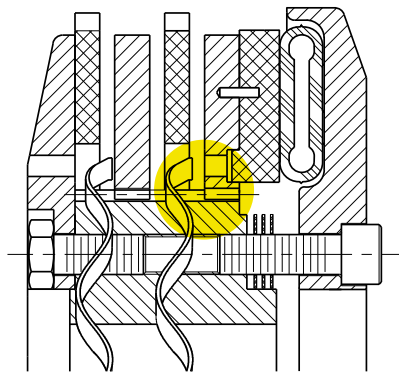

ENLARGED VIEW

This is just another of WPT's many innovations to give our customers the best possible product available.

# Power Grip Clutches

The Power Grip Clutch is designed to accommodate in-line mounting for heavy duty power transmission. Used in conjunction with either a quick change or standard driving adapter, shown on page 3, the Power Grip Clutch is useful as a coupling clutch for shaft to shaft applications.

Split friction discs and airtubes are available to assist with maintenance. Air actuation with the airtube design allows for smooth control and remote actuation via a simple air valve.

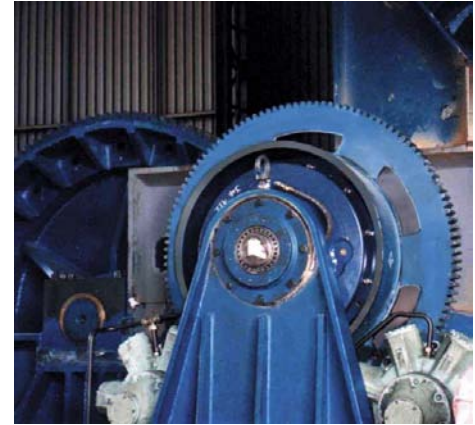

## SPECIFICATIONS

Model	Torque Rating @ 100 psi (lb-in) / 7 bar (Nm)				Maximum Speed rpm	Weight and Inertia				Bore Range	
	Static Torque		Dynamic Torque			Total Weight	Total Inertia	Ring & FD Weight	Ring & FD Inertia	Minimum	Maximum
	lb-in	Nm	lb-in	Nm		lbs (kgs)	lbft <sup>2</sup> (wr <sup>2</sup> ) (kgm <sup>2</sup> (J))	lbs (kgs)	lbft <sup>2</sup> (wr <sup>2</sup> ) (kgm <sup>2</sup> (J))	inches (mm)	inches (mm)
108	7,300	835	5,500	630	3,600	30 (14)	2.4 (0.102)	8.3 (3.7)	1.2 (0.048)	0.94 (23.8)	1.94 (49.2)
208	14,600	1,670	11,000	1,260	3,600	20 (23)	4.3 (0.179)	17 (7.5)	2.3 (0.098)	0.94 (23.8)	1.94 (49.2)
308	21,900	2,505	16,500	1,890	3,600	67 (30)	6.0 (0.254)	25 (11)	3.5 (0.149)	1.13 (28.6)	1.94 (49.2)
111	16,600	1,905	12,450	1,425	2,650	55 (25)	9.2 (0.388)	19 (9)	5.4 (0.227)	1.25 (31.8)	3.0 (76.2)
211	33,200	3,810	24,900	2,850	2,650	96 (44)	16.4 (0.690)	37 (17)	10.4 (0.438)	1.25 (31.8)	3.0 (76.2)
311	49,800	5,715	37,350	4,275	2,650	132 (60)	22.9 (0.965)	52 (24)	15.3 (0.645)	1.25 (31.8)	3.0 (76.2)
114	29,150	3,345	21,900	2,510	2,180	124 (56)	35.2 (1.49)	38 (17)	17.1 (0.721)	2.13 (54.0)	3.25 (82.6)
214	58,300	6,690	43,800	5,020	2,180	176 (80)	47.9 (2.02)	57 (26)	24.6 (1.04)	2.13 (54.0)	3.25 (82.6)
314	87,450	10,035	65,700	7,530	2,180	239 (109)	72.0 (3.04)	97 (44)	42.3 (1.79)	2.13 (54.0)	3.25 (82.6)
114H	35,400	4,065	26,600	3,050	2,180	161 (73)	41.2 (1.74)	38 (17)	17.1 (0.721)	2.13 (54.0)	3.25 (82.6)
214H	70,800	8,130	53,200	6,100	2,180	212 (96)	57.1 (2.41)	57 (26)	24.6 (1.04)	2.13 (54.0)	3.25 (82.6)
314H	106,200	12,195	79,800	9,150	2,180	290 (132)	79.6 (3.36)	97 (44)	42.3 (1.79)	2.13 (54.0)	3.25 (82.6)
116	39,750	4,560	29,800	3,420	1,900	218 (99)	60.6 (2.56)	41 (19)	23.1 (0.973)	2.13 (54.0)	3.41 (86.6)
216	79,500	9,120	59,600	6,840	1,900	296 (134)	87.9 (3.71)	79 (36)	41.8 (1.76)	2.13 (54.0)	3.41 (86.6)
316	119,250	13,680	89,400	10,260	1,900	380 (172)	117 (4.93)	116 (53)	61.2 (2.58)	2.13 (54.0)	3.41 (86.6)
118	66,400	7,620	49,800	5,715	1,750	277 (125)	90 (3.78)	44 (20)	28.3 (1.19)	2.38 (60.3)	3.88 (98.4)
218	132,800	15,240	99,600	11,430	1,750	397 (180)	142 (6.00)	95 (43)	61.6 (2.60)	2.38 (60.3)	3.88 (98.4)
318	199,200	22,860	149,400	17,145	1,750	501 (227)	189 (7.97)	144 (66)	93.3 (3.94)	2.38 (60.3)	3.88 (98.4)
118H	82,000	9,405	61,500	7,055	1,750	294 (134)	100 (4.22)	44 (20)	28.3 (1.19)	2.38 (60.3)	3.88 (98.4)
218H	164,000	18,810	123,000	14,110	1,750	414 (188)	151 (6.36)	95 (43)	61.6 (2.60)	2.38 (60.3)	3.88 (98.4)
318H	246,000	28,215	184,500	21,165	1,750	525 (238)	199 (8.40)	144 (66)	93.3 (3.94)	2.38 (60.3)	3.88 (98.4)
121	95,400	10,950	71,500	8,205	1,525	390 (177)	179 (7.57)	63 (29)	56.1 (2.37)	2.75 (69.9)	4.75 (120.7)
221	190,800	21,900	143,000	16,410	1,525	566 (257)	283 (12.0)	138 (63)	124 (5.22)	2.75 (69.9)	4.75 (120.7)
321	286,200	32,850	214,500	24,615	1,525	738 (335)	381 (16.1)	210 (95)	186 (7.83)	2.75 (69.9)	4.75 (120.7)
124H	160,600	18,435	120,500	13,830	1,350	593 (269)	373 (15.7)	115 (52)	132 (5.55)	2.75 (69.9)	4.75 (120.7)
224H	321,200	36,870	241,000	27,660	1,350	800 (363)	510 (21.5)	190 (86)	207 (8.75)	2.75 (69.9)	4.75 (120.7)
324H	481,800	55,305	361,500	41,490	1,350	993 (450)	622 (26.2)	250 (113)	259 (10.9)	2.75 (69.9)	4.75 (120.7)
124SHD	206,950	23,745	155,200	17,810	1,350	613 (278)	380 (16.1)	115 (52)	132 (5.55)	2.75 (69.9)	4.75 (120.7)
224SHD	413,900	47,490	310,400	35,620	1,350	820 (372)	517 (21.8)	190 (86)	207 (8.75)	2.75 (69.9)	4.75 (120.7)
324SHD	620,850	71,235	465,600	53,430	1,350	1013 (460)	629 (26.6)	250 (113)	259 (10.9)	2.75 (69.9)	4.75 (120.7)
227	361,100	41,450	270,800	31,080	1,200	926 (420)	696 (29.4)	190 (86)	250 (10.6)	3.50 (88.9)	7.00 (177.8)
327	541,650	62,175	406,200	46,620	1,200	1,243 (564)	949 (40.1)	302 (137)	399 (16.8)	3.50 (88.9)	7.00 (177.8)
230H	690,800	79,260	518,000	59,450	1,100	1,470 (667)	1,315 (55.5)	292 (132)	444 (18.7)	3.88 (98.5)	7.00 (177.8)
330H	1,036,200	118,890	777,000	89,175	1,100	1,868 (847)	1,704 (71.9)	427 (194)	647 (27.3)	3.88 (98.5)	7.00 (177.8)
236	1,063,250	122,000	797,400	91,500	900	2,145 (973)	2,955 (125)	426 (193)	956 (40.4)	5.00 (127.0)	9.0 (228.6)
336	1,594,875	183,000	1,196,100	137,250	900	2,907 (1,318)	3,319 (140)	644 (292)	980 (41.4)	5.00 (127.0)	9.0 (228.6)
242	1,518,200	174,200	1,138,600	130,650	750	3,135 (1,422)	5,466 (231)	676 (307)	2,235 (94.3)	7.00 (177.8)	11.0 (279.4)
342	2,277,300	261,300	1,707,900	195,975	750	4,062 (1,843)	7,478 (316)	1,053 (478)	3,489 (147)	7.00 (177.8)	11.0 (279.4)
248	2,832,000	325,000	2,124,400	243,800	650	4,688 (2,127)	10,743 (453)	799 (362)	3,386 (143)	8.00 (203.2)	12.0 (304.8)
348	4,248,000	487,500	3,186,600	365,700	650	5,801 (2,631)	13,501 (570)	1,138 (516)	4,786 (202)	8.00 (203.2)	12.0 (304.8)
260	5,670,000	650,900	4,252,500	488,100	525	7,450 (3,379)	22,752 (960)	1,470 (667)	8,546 (361)	11.00 (279.4)	15.0 (381.0)
360	8,505,000	976,350	6,378,750	732,150	525	9,431 (4,278)	30,978 (1,307)	2,242 (1,017)	13,028 (550)	11.00 (279.4)	15.0 (381.0)
460	11,340,000	1,301,800	8,505,000	976,200	525	11,656 (5,287)	39,545 (1,669)	3,060 (1,388)	17,868 (754)	11.00 (279.4)	15.0 (381.0)

Consult WPT Engineering for application assistance and applicable safety/service factors.

Larger bore sizes may be accommodated, consult WPT Engineering.

# Power Grip Clutches

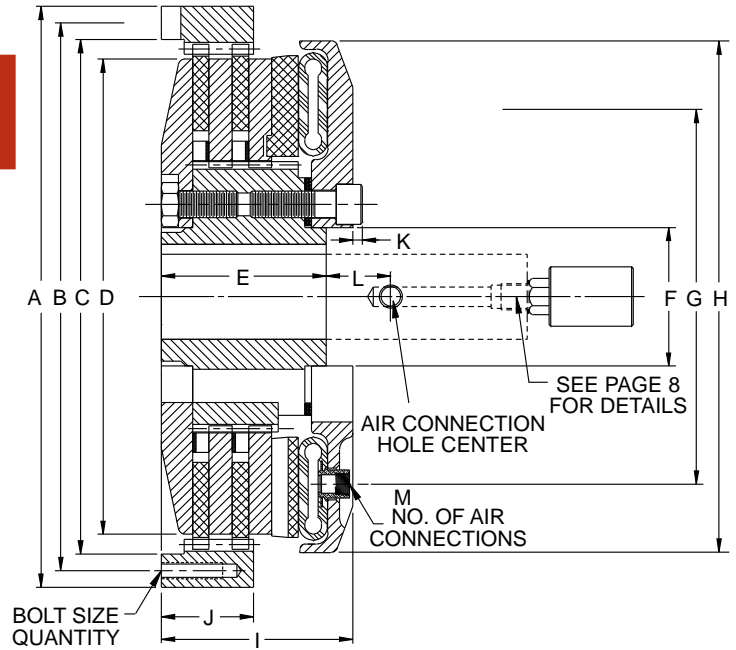
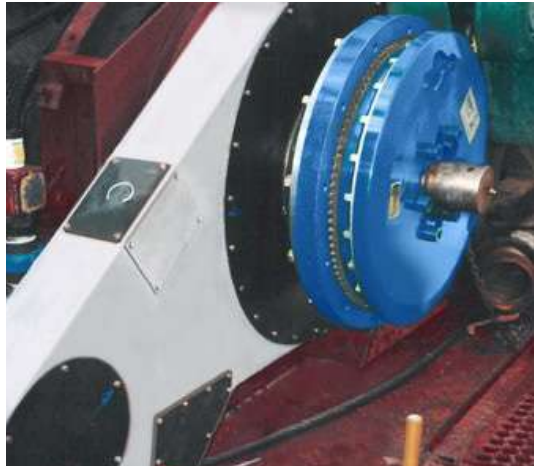

## DIMENSIONS inches (mm)

SIZE	A	B	BOLT SIZE	QTY	C		D	E	F	G	H	I	J	K
					+.003/-.000	(+.076/-.000)								
108	10 3/8 (263.53)	9.625 (244.48)	1/2-13	6	8.872 (225.35)	8 (203.21)	2 3/4 (69.85)	1 61/64 (49.53)	6 5/8 (168.28)	9 5/8 (244.48)	3 7/8 (98.43)	1 3/8 (34.93)	9/32 (7.14)	
208	10 3/8 (263.53)	9.625 (244.48)	1/2-13	6	8.872 (225.35)	8 (203.21)	4 1/8 (104.78)	1 61/64 (49.53)	6 5/8 (168.28)	9 5/8 (244.48)	5 1/4 (133.35)	2 3/4 (69.85)	9/32 (7.14)	
308	10 3/8 (263.53)	9.625 (244.48)	1/2-13	6	8.872 (225.35)	8 (203.21)	5 1/2 (139.70)	1 61/64 (49.53)	6 5/8 (168.28)	9 5/8 (244.48)	6 5/8 (168.28)	4 1/8 (104.78)	9/32 (7.14)	
111	14 3/8 (365.13)	13 3/8 (339.73)	5/8-11	8	12.375 (314.33)	11 (279.40)	3 (76.20)	3 1/64 (76.60)	8 1/2 (215.90)	11 15/16 (303.21)	4 1/8 (104.78)	1 1/2 (38.10)	7/16 (11.11)	
211	14 3/8 (365.13)	13 3/8 (339.73)	5/8-11	8	12.375 (314.33)	11 (279.40)	4 1/4 (107.95)	3 1/64 (76.60)	8 1/2 (215.90)	11 15/16 (303.21)	5 3/8 (136.53)	2 7/8 (73.03)	7/16 (11.11)	
311	14 3/8 (365.13)	13 3/8 (339.73)	5/8-11	8	12.375 (314.33)	11 (279.40)	5 9/16 (141.29)	3 1/64 (76.60)	8 1/2 (215.90)	11 15/16 (303.21)	6 11/16 (169.86)	4 3/16 (106.36)	7/16 (11.11)	
114	17 1/2 (444.50)	16 1/4 (412.75)	5/8-11	6	15.125 (384.18)	14 (355.60)	4 5/16 (109.54)	4 1/2 (114.30)	10 3/4 (273.05)	14 3/8 (365.13)	5 1/8 (130.18)	1 7/8 (47.63)	11/32 (8.73)	
214	17 1/2 (444.50)	16 1/4 (412.75)	5/8-11	6	15.125 (384.18)	14 (355.60)	5 3/4 (146.05)	4 1/2 (114.30)	10 3/4 (273.05)	14 3/8 (365.13)	6 9/16 (166.69)	3 1/4 (82.55)	11/32 (8.73)	
314	17 1/2 (444.50)	16 1/4 (412.75)	5/8-11	6	15.125 (384.18)	14 (355.60)	7 3/16 (182.56)	4 1/2 (114.30)	10 3/4 (273.05)	14 3/8 (365.13)	8 (203.20)	4 3/4 (120.65)	11/32 (8.73)	
114H	17 1/2 (444.50)	16 1/4 (412.75)	5/8-11	6	15.125 (384.18)	14 (355.60)	4 5/16 (109.54)	4 1/2 (114.30)	12 1/2 (317.50)	16 5/16 (414.34)	5 1/8 (130.18)	1 7/8 (47.63)	-	
214H	17 1/2 (444.50)	16 1/4 (412.75)	5/8-11	6	15.125 (384.18)	14 (355.60)	5 3/4 (146.05)	4 1/2 (114.30)	12 1/2 (317.50)	16 5/16 (414.34)	6 5/8 (168.28)	3 1/4 (82.55)	-	
314H	17 1/2 (444.50)	16 1/4 (412.75)	5/8-11	6	15.125 (384.18)	14 (355.60)	7 3/16 (182.56)	4 1/2 (114.30)	12 1/2 (317.50)	16 5/16 (414.34)	8 (203.20)	4 3/4 (120.65)	-	
116	20 (508.00)	18 3/4 (476.25)	5/8-11	6	17.500 (444.50)	16 (406.40)	4 5/16 (109.54)	4 7/8 (123.83)	1 1/2 (317.50)	16 19/64 (413.94)	5 3/16 (131.76)	1 7/8 (47.63)	3/4 (19.05)	
216	20 (508.00)	18 3/4 (476.25)	5/8-11	6	17.500 (444.50)	16 (406.40)	5 3/4 (146.05)	4 7/8 (123.83)	1 1/2 (317.50)	16 19/64 (413.94)	6 9/16 (166.69)	3 1/4 (82.55)	3/4 (19.05)	
316	20 (508.00)	18 3/4 (476.25)	5/8-11	6	17.500 (444.50)	16 (406.40)	7 1/4 (184.15)	4 7/8 (123.83)	1 1/2 (317.50)	16 19/64 (413.94)	8 (203.20)	4 3/4 (120.65)	3/4 (19.05)	
118	22 (558.80)	20 3/4 (527.05)	5/8-11	6	19.500 (495.30)	18 (457.20)	4 3/4 (120.65)	5 1/4 (133.35)	14 3/16 (360.36)	19 3/8 (492.13)	5 11/16 (144.46)	1 15/16 (49.21)	3/8 (9.53)	
218	22 (558.80)	20 3/4 (527.05)	5/8-11	6	19.500 (495.30)	18 (457.20)	6 1/4 (158.75)	5 1/4 (133.35)	14 3/16 (360.36)	19 3/8 (492.13)	7 1/4 (184.15)	3 1/2 (88.90)	3/8 (9.53)	
318	22 (558.80)	20 3/4 (527.05)	5/8-11	6	19.500 (495.30)	18 (457.20)	7 3/4 (196.85)	5 1/4 (133.35)	14 3/16 (360.36)	19 3/8 (492.13)	8 7/8 (225.43)	5 1/8 (130.18)	3/8 (9.53)	
118H	22 (558.80)	20 3/4 (527.05)	5/8-11	6	19.500 (495.30)	18 (457.20)	4 3/4 (120.65)	5 1/4 (133.35)	16 (406.40)	21 5/16 (541.34)	5 11/16 (144.46)	1 15/16 (49.21)	1 (25.40)	
218H	22 (558.80)	20 3/4 (527.05)	5/8-11	6	19.500 (495.30)	18 (457.20)	6 1/4 (158.75)	5 1/4 (133.35)	16 (406.40)	21 5/16 (541.34)	7 1/4 (184.15)	3 1/2 (88.90)	1 (25.40)	
318H	22 (558.80)	20 3/4 (527.05)	5/8-11	6	19.500 (495.30)	18 (457.20)	7 3/4 (196.85)	5 1/4 (133.35)	16 (406.40)	21 5/16 (541.34)	8 3/4 (222.25)	5 1/8 (130.18)	1 (25.40)	
121	25 (635.00)	23 3/4 (603.25)	5/8-11	6	22.500 (571.50)	21 (533.40)	5 7/8 (149.23)	7 (177.80)	16 (406.40)	21 5/16 (541.34)	6 9/16 (166.69)	2 1/2 (63.50)	1 (25.40)	
221	25 (635.00)	23 3/4 (603.25)	5/8-11	6	22.500 (571.50)	21 (533.40)	7 1/4 (184.15)	7 (177.80)	16 (406.40)	21 5/16 (541.34)	8 3/8 (212.73)	4 3/8 (111.13)	1 (25.40)	
321	25 (635.00)	23 3/4 (603.25)	5/8-11	6	22.500 (571.50)	21 (533.40)	8 5/8 (219.08)	7 (177.80)	16 (406.40)	21 5/16 (541.34)	10 1/8 (257.18)	6 1/4 (158.75)	1 (25.40)	
124H	28 (711.20)	26 3/4 (679.45)	5/8-11	6	25.500 (647.70)	24 (609.60)	5 7/8 (149.23)	7 (177.80)	21 (533.40)	27 (685.80)	6 3/4 (171.45)	2 13/16 (71.44)	1 (25.40)	
224H	28 (711.20)	26 3/4 (679.45)	5/8-11	6	25.500 (647.70)	24 (609.60)	7 1/4 (184.15)	7 (177.80)	21 (533.40)	27 (685.80)	8 1/2 (215.90)	4 1/2 (114.30)	1 (25.40)	
324H	28 (711.20)	26 3/4 (679.45)	5/8-11	6	25.500 (647.70)	24 (609.60)	9 3/8 (238.13)	7 (177.80)	21 (533.40)	27 (685.80)	10 1/2 (266.70)	6 1/4 (158.75)	1 (25.40)	
124SHD	28 (711.20)	26 3/4 (679.45)	5/8-11	6	25.500 (647.70)	24 (609.60)	5 7/8 (149.23)	7 (177.80)	21 (533.40)	27 (685.80)	6 7/8 (174.63)	2 13/16 (71.44)	1 (25.40)	
224SHD	28 (711.20)	26 3/4 (679.45)	5/8-11	6	25.500 (647.70)	24 (609.60)	7 1/4 (184.15)	7 (177.80)	21 (533.40)	27 (685.80)	8 1/2 (215.90)	4 1/2 (114.30)	1 (25.40)	
324SHD	28 (711.20)	26 3/4 (679.45)	5/8-11	6	25.500 (647.70)	24 (609.60)	9 3/8 (238.13)	7 (177.80)	21 (533.40)	27 (685.80)	10 1/2 (266.70)	6 1/4 (158.75)	1 (25.40)	
227	31 (787.40)	29 3/4 (755.65)	5/8-11	12	28.500 (723.90)	27 (685.80)	7 (177.80)	9 (228.60)	21 (533.40)	27 (685.80)	8 3/4 (222.25)	4 1/2 (114.30)	1 (25.40)	
327	31 (787.40)	29 3/4 (755.65)	5/8-11	12	28.500 (723.90)	27 (685.80)	9 (228.60)	9 (228.60)	21 (533.40)	27 (685.80)	10 3/4 (273.05)	6 1/2 (165.10)	1 (25.40)	
230H	34 (863.60)	32 3/4 (831.85)	5/8-11	12	31.500 (800.10)	30 (762.00)	8 1/2 (215.90)	9 (228.60)	24 3/4 (628.65)	32 3/8 (822.33)	10 3/4 (273.05)	5 5/8 (142.88)	1/4 (6.35)	
330H	34 (863.60)	32 3/4 (831.85)	5/8-11	12	31.500 (800.10)	30 (762.00)	10 7/8 (276.23)	9 (228.60)	24 3/4 (628.65)	32 3/8 (822.33)	12 3/4 (323.85)	8 1/8 (206.38)	1/4 (6.35)	
236	41 (1041.40)	39 3/4 (1009.65)	5/8-11	16	38.500 (977.90)	36 (914.40)	9 3/4 (247.65)	13 1/2 (342.90)	30 1/2 (774.70)	38 1/4 (971.55)	11 7/8 (301.63)	6 1/4 (158.75)	1/4 (6.35)	
336	41 (1041.40)	39 3/4 (1009.65)	5/8-11	16	38.500 (977.90)	36 (914.40)	12 7/8 (327.03)	13 1/2 (342.90)	30 1/2 (774.70)	38 1/4 (971.55)	14 3/4 (374.65)	9 1/8 (231.78)	1/4 (6.35)	
242	49 1/4 (1250.95)	47 1/4 (1200.15)	1-8	12	45.000 (1143.00)	42 (1066.80)	10 1/2 (266.70)	21 1/16 (534.99)	35 (889.00)	44 1/8 (1120.78)	11 3/8 (288.93)	6 1/2 (165.10)	1 1/4 (31.75)	
342	49 1/4 (1250.95)	47 1/4 (1200.15)	1-8	12	45.000 (1143.00)	42 (1066.80)	11 7/8 (301.63)	21 1/16 (534.99)	35 (889.00)	44 1/8 (1120.78)	14 1/8 (358.78)	9 5/8 (244.48)	1 1/4 (31.75)	
248	56 (1422.41)	54 (1371.61)	1-8	12	52.000 (1320.81)	48 (1219.20)	10 7/8 (276.23)	21 (533.40)	40 (1016.00)	52 3/8 (1330.33)	13 (330.20)	7 1/2 (190.50)	3/4 (19.05)	
348	56 (1422.41)	54 (1371.61)	1-8	12	52.000 (1320.81)	48 (1219.20)	13 5/8 (346.08)	21 (533.40)	40 (1016.00)	52 3/8 (1330.33)	15 3/4 (400.05)	9 7/8 (250.83)	3/4 (19.05)	
260	66 3/4 (1695.46)	64 3/4 (1644.66)	1-8	24	62.750 (1593.86)	60 (1524.01)	16 1/4 (412.75)	22 5/8 (574.68)	46 1/2 (1181.10)	61 1/2 (1562.11)	16 1/4 (412.75)	9 (228.60)	1/4 (6.35)	
360	66 3/4 (1695.46)	64 3/4 (1644.66)	1-8	24	62.750 (1593.86)	60 (1524.01)	20 (508.00)	22 5/8 (574.68)	46 1/2 (1181.10)	61 1/2 (1562.11)	20 (508.00)	13 (330.20)	1/4 (6.35)	
460	66 3/4 (1695.46)	64 3/4 (1644.66)	1-8	24	62.750 (1593.86)	60 (1524.01)	23 1/2 (596.90)	22 5/8 (574.68)	46 1/2 (1181.10)	61 1/2 (1562.11)	23 1/2 (596.90)	16 1/2 (419.10)	1/4 (6.35)	

Certified prints available on request. See page 8 for accessories and typical hosing arrangements.

### Quick Change Driving Adapter

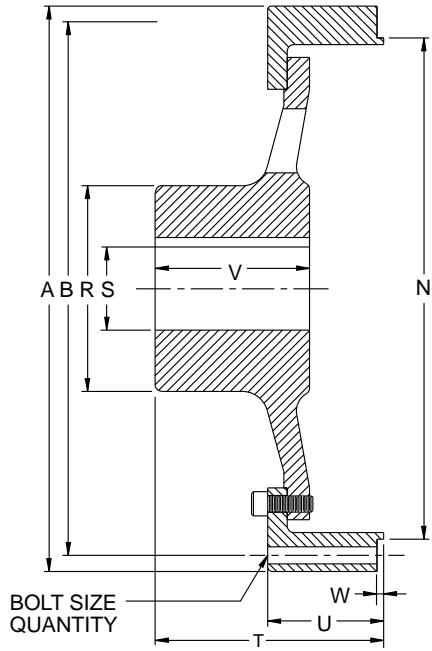

### Standard Driving Adapter

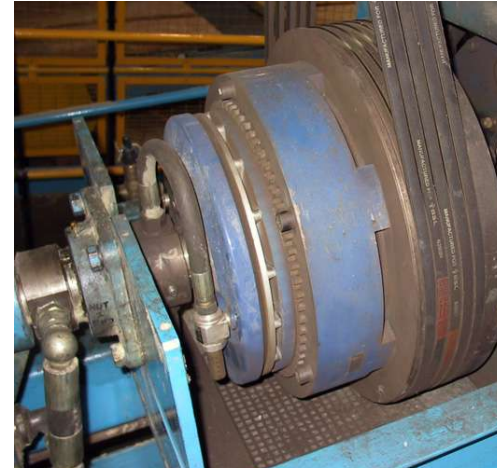
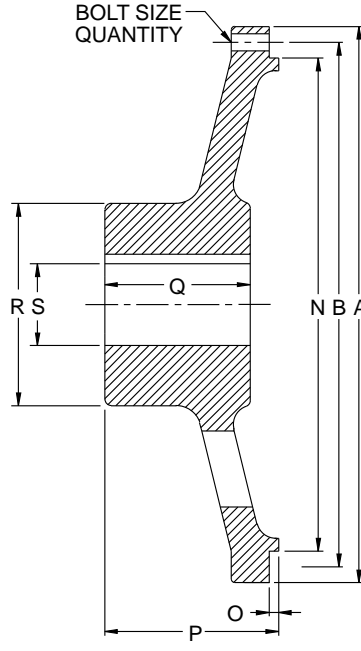

L	M QTY	N		O	P	Q	R	S		T	U	W	V	SIZE
		+ .000/- .003 (+ .000/- .076)						MIN*	MAX*					
2 1/4 (57.15)	2	8.872 (225.35)		1/8 (3.18)	3 1/8 (79.38)	3 (76.20)	3 3/4 (95.25)	15/16 (23.81)	2 5/8 (66.68)	-	-	-	-	108
2 1/4 (57.15)	2	8.872 (225.35)		1/8 (3.18)	3 1/8 (79.38)	3 (76.20)	3 3/4 (95.25)	15/16 (23.81)	2 5/8 (66.68)	-	-	-	-	208
2 1/4 (57.15)	2	8.872 (225.35)		1/8 (3.18)	3 1/8 (79.38)	3 (76.20)	3 3/4 (95.25)	15/16 (23.81)	2 5/8 (66.68)	-	-	-	-	308
2 1/2 (63.50)	2	12.374 (314.30)		1/8 (3.18)	3 5/8 (92.08)	3 1/4 (82.55)	6 1/4 (158.75)	1 3/8 (34.93)	4 7/16 (111.13)	-	-	-	-	111
2 1/2 (63.50)	2	12.374 (314.30)		1/8 (3.18)	3 5/8 (92.08)	3 1/4 (82.55)	6 1/4 (158.75)	1 3/8 (34.93)	4 7/16 (111.13)	-	-	-	-	211
2 1/2 (63.50)	2	12.374 (314.30)		1/8 (3.18)	3 5/8 (92.08)	3 1/4 (82.55)	6 1/4 (158.75)	1 3/8 (34.93)	4 7/16 (111.13)	-	-	-	-	311
2 1/4 (57.15)	2	15.124 (384.15)		1/4 (6.35)	5 3/8 (136.53)	4 3/4 (120.65)	7 (177.80)	1 5/8 (41.28)	4 7/8 (123.83)	5 1/2 (139.70)	3 3/8 (85.73)	1/8 (3.18)	3 1/4 (82.55)	114
2 1/4 (57.15)	2	15.124 (384.15)		1/4 (6.35)	5 3/8 (136.53)	4 3/4 (120.65)	7 (177.80)	1 5/8 (41.28)	4 7/8 (123.83)	5 1/2 (139.70)	3 3/8 (85.73)	1/8 (3.18)	3 1/4 (82.55)	214
2 1/4 (57.15)	2	15.124 (384.15)		1/4 (6.35)	5 3/8 (136.53)	4 3/4 (120.65)	7 (177.80)	1 5/8 (41.28)	4 7/8 (123.83)	5 1/2 (139.70)	3 3/8 (85.73)	1/8 (3.18)	3 1/4 (82.55)	314
2 1/4 (57.15)	2	15.124 (384.15)		1/4 (6.35)	5 3/8 (136.53)	4 3/4 (120.65)	7 (177.80)	1 5/8 (41.28)	4 7/8 (123.83)	5 1/2 (139.70)	3 3/8 (85.73)	1/8 (3.18)	3 1/4 (82.55)	114H
2 1/4 (57.15)	2	15.124 (384.15)		1/4 (6.35)	5 3/8 (136.53)	4 3/4 (120.65)	7 (177.80)	1 5/8 (41.28)	4 7/8 (123.83)	5 1/2 (139.70)	3 3/8 (85.73)	1/8 (3.18)	3 1/4 (82.55)	214H
2 1/4 (57.15)	2	15.124 (384.15)		1/4 (6.35)	5 3/8 (136.53)	4 3/4 (120.65)	7 (177.80)	1 5/8 (41.28)	4 7/8 (123.83)	5 1/2 (139.70)	3 3/8 (85.73)	1/8 (3.18)	3 1/4 (82.55)	314H
2 1/4 (57.15)	2	17.499 (444.48)		1/4 (6.35)	6 1/8 (155.58)	5 1/2 (139.70)	7 (177.80)	1 7/8 (47.63)	4 7/8 (123.83)	7 9/16 (192.09)	3 11/16 (93.66)	1/8 (3.18)	5 1/2 (139.70)	116
2 1/4 (57.15)	2	17.499 (444.48)		1/4 (6.35)	6 1/8 (155.58)	5 1/2 (139.70)	7 (177.80)	1 7/8 (47.63)	4 7/8 (123.83)	7 9/16 (192.09)	3 11/16 (93.66)	1/8 (3.18)	5 1/2 (139.70)	216
2 1/4 (57.15)	2	17.499 (444.48)		1/4 (6.35)	6 1/8 (155.58)	5 1/2 (139.70)	7 (177.80)	1 7/8 (47.63)	4 7/8 (123.83)	7 9/16 (192.09)	3 11/16 (93.66)	1/8 (3.18)	5 1/2 (139.70)	316
2 7/16 (61.91)	3	19.499 (495.28)		3/8 (9.53)	6 7/8 (174.63)	5 3/4 (146.05)	8 (203.20)	2 1/4 (57.15)	5 5/8 (142.88)	8 (203.20)	4 1/2 (114.30)	1/4 (6.35)	6 (152.40)	118
2 7/16 (61.91)	3	19.499 (495.28)		3/8 (9.53)	6 7/8 (174.63)	5 3/4 (146.05)	8 (203.20)	2 1/4 (57.15)	5 5/8 (142.88)	8 (203.20)	4 1/2 (114.30)	1/4 (6.35)	6 (152.40)	218
2 7/16 (61.91)	3	19.499 (495.28)		3/8 (9.53)	6 7/8 (174.63)	5 3/4 (146.05)	8 (203.20)	2 1/4 (57.15)	5 5/8 (142.88)	8 (203.20)	4 1/2 (114.30)	1/4 (6.35)	6 (152.40)	318
2 7/16 (61.91)	3	19.499 (495.28)		3/8 (9.53)	6 7/8 (174.63)	5 3/4 (146.05)	8 (203.20)	2 1/4 (57.15)	5 5/8 (142.88)	8 (203.20)	4 1/2 (114.30)	1/4 (6.35)	6 (152.40)	118H
2 7/16 (61.91)	3	19.499 (495.28)		3/8 (9.53)	6 7/8 (174.63)	5 3/4 (146.05)	8 (203.20)	2 1/4 (57.15)	5 5/8 (142.88)	8 (203.20)	4 1/2 (114.30)	1/4 (6.35)	6 (152.40)	218H
2 7/16 (61.91)	3	19.499 (495.28)		3/8 (9.53)	6 7/8 (174.63)	5 3/4 (146.05)	8 (203.20)	2 1/4 (57.15)	5 5/8 (142.88)	8 (203.20)	4 1/2 (114.30)	1/4 (6.35)	6 (152.40)	318H
2 3/8 (60.33)	3	22.499 (571.48)		1/4 (6.35)	6 3/4 (171.45)	6 (152.40)	9 1/2 (241.30)	2 1/2 (63.50)	6 5/8 (168.28)	10 1/2 (266.70)	6 1/2 (165.10)	1/4 (6.35)	6 (152.40)	121
2 3/8 (60.33)	3	22.499 (571.48)		1/4 (6.35)	6 3/4 (171.45)	6 (152.40)	9 1/2 (241.30)	2 1/2 (63.50)	6 5/8 (168.28)	10 1/2 (266.70)	6 1/2 (165.10)	1/4 (6.35)	6 (152.40)	221
2 3/8 (60.33)	3	22.499 (571.48)		1/4 (6.35)	6 3/4 (171.45)	6 (152.40)	9 1/2 (241.30)	2 1/2 (63.50)	6 5/8 (168.28)	10 1/2 (266.70)	6 1/2 (165.10)	1/4 (6.35)	6 (152.40)	321
2 3/4 (69.85)	3	25.498 (647.65)		-	-	-	10 (254.00)	3 (76.20)	7 (177.80)	11 1/8 (282.58)	5 5/8 (142.88)	1/8 (3.18)	7 5/16 (185.74)	124H
2 3/4 (69.85)	3	25.498 (647.65)		-	-	-	10 (254.00)	3 (76.20)	7 (177.80)	11 1/8 (282.58)	5 5/8 (142.88)	1/8 (3.18)	7 5/16 (185.74)	224H
2 3/4 (69.85)	3	25.498 (647.65)		-	-	-	10 (254.00)	3 (76.20)	7 (177.80)	11 1/8 (282.58)	5 5/8 (142.88)	1/8 (3.18)	7 5/16 (185.74)	324H
2 3/4 (69.85)	2	25.498 (647.65)		-	-	-	10 (254.00)	3 (76.20)	7 (177.80)	11 1/8 (282.58)	5 5/8 (142.88)	1/8 (3.18)	7 5/16 (185.74)	124SHD
2 3/4 (69.85)	2	25.498 (647.65)		-	-	-	10 (254.00)	3 (76.20)	7 (177.80)	11 1/8 (282.58)	5 5/8 (142.88)	1/8 (3.18)	7 5/16 (185.74)	224SHD
2 3/4 (69.85)	2	25.498 (647.65)		-	-	-	10 (254.00)	3 (76.20)	7 (177.80)	11 1/8 (282.58)	5 5/8 (142.88)	1/8 (3.18)	7 5/16 (185.74)	324SHD
2 3/8 (60.33)	3	28.498 (723.85)		-	-	-	11 1/2 (292.10)	5 (127.00)	8 (203.20)	7 15/16 (201.61)	2 3/8 (60.33)	1/8 (3.18)	7 5/16 (185.74)	227
2 3/8 (60.33)	3	28.498 (723.85)		-	-	-	11 1/2 (292.10)	5 (127.00)	8 (203.20)	7 15/16 (201.61)	2 3/8 (60.33)	1/8 (3.18)	7 5/16 (185.74)	327
2 7/8 (73.03)	4	31.498 (800.05)		-	-	-	14 (355.60)	3 1/2 (88.90)	9 3/4 (247.65)	12 1/2 (317.50)	6 (152.40)	1/4 (6.35)	8 3/4 (222.25)	230H
2 7/8 (73.03)	4	31.498 (800.05)		-	-	-	14 (355.60)	3 1/2 (88.90)	9 3/4 (247.65)	12 1/2 (317.50)	6 (152.40)	1/4 (6.35)	8 3/4 (222.25)	330H
2 7/8 (73.03)	4	38.498 (977.85)		-	-	-	14 (355.60)	6 (152.40)	9 3/4 (247.65)	12 1/4 (311.15)	4 3/8 (111.13)	1/4 (6.35)	10 (254.00)	236
2 7/8 (73.03)	4	38.498 (977.85)		-	-	-	14 (355.60)	6 (152.40)	9 3/4 (247.65)	12 1/4 (311.15)	4 3/8 (111.13)	1/4 (6.35)	10 (254.00)	336
3 1/2 (88.90)	4	44.998 (1142.95)		-	-	-	18 (457.20)	7 (177.80)	12 9/16 (319.09)	13 7/16 (341.31)	5 15/16 (150.81)	1/4 (6.35)	10 (254.00)	242
3 1/2 (88.90)	4	44.998 (1142.95)		-	-	-	18 (457.20)	7 (177.80)	12 9/16 (319.09)	13 7/16 (341.31)	5 15/16 (150.81)	1/4 (6.35)	10 (254.00)	342
3 1/2 (88.90)	4	51.998 (1320.75)		-	-	-	20 (508.00)	8 (203.20)	14 (355.60)	16 3/4 (425.45)	6 5/8 (168.28)	1/2 (12.70)	13 5/8 (346.08)	248
3 1/2 (88.90)	4	51.998 (1320.75)		-	-	-	20 (508.00)	8 (203.20)	14 (355.60)	16 3/4 (425.45)	6 5/8 (168.28)	1/2 (12.70)	13 5/8 (346.08)	348
2 (50.80)	6	62.748 (1593.81)		-	-	-	24 (609.60)	10 (254.00)	16 3/4 (425.45)	24 1/8 (612.78)	11 7/8 (301.63)	3/8 (9.53)	16 1/4 (412.75)	260
2 (50.80)	6	62.748 (1593.81)		-	-	-	24 (609.60)	10 (254.00)	16 3/4 (425.45)	24 1/8 (612.78)	11 7/8 (301.63)	3/8 (9.53)	16 1/4 (412.75)	360
2 (50.80)	6	62.748 (1593.81)		-	-	-	24 (609.60)	10 (254.00)	16 3/4 (425.45)	24 1/8 (612.78)	11 7/8 (301.63)	3/8 (9.53)	16 1/4 (412.75)	460

\*For clutch min/max bores see Specification Table on page 1.

# Power Grip High Speed Clutches

Power Grip High Speed Clutches are designed to withstand severe applications mounted to internal combustion engines. The drive rings will fit standard SAE industrial flywheels. Heavy duty laminated gear teeth friction discs are designed to withstand heavy shock loads and torsional vibrations. Clutches are balanced to the maximum speeds shown below. Do not exceed the capacities in the chart below for internal combustion engines.

Clutch Size	Max hp (Kw) per 100 rpm	Max hp (Kw) @ max rpm	Max Speed rpm
214H	22 (16)	500 (370)	2,500
314H	33 (25)	750 (560)	2,500
218	38 (28)	800 (600)	2,300
318	60 (45)	1,250 (930)	2,300
321	117 (87)	2,100 (1565)	1,950

For starting high inertia loads requiring more than a 2-3 second start, consult WPT Engineering for selection assistance.

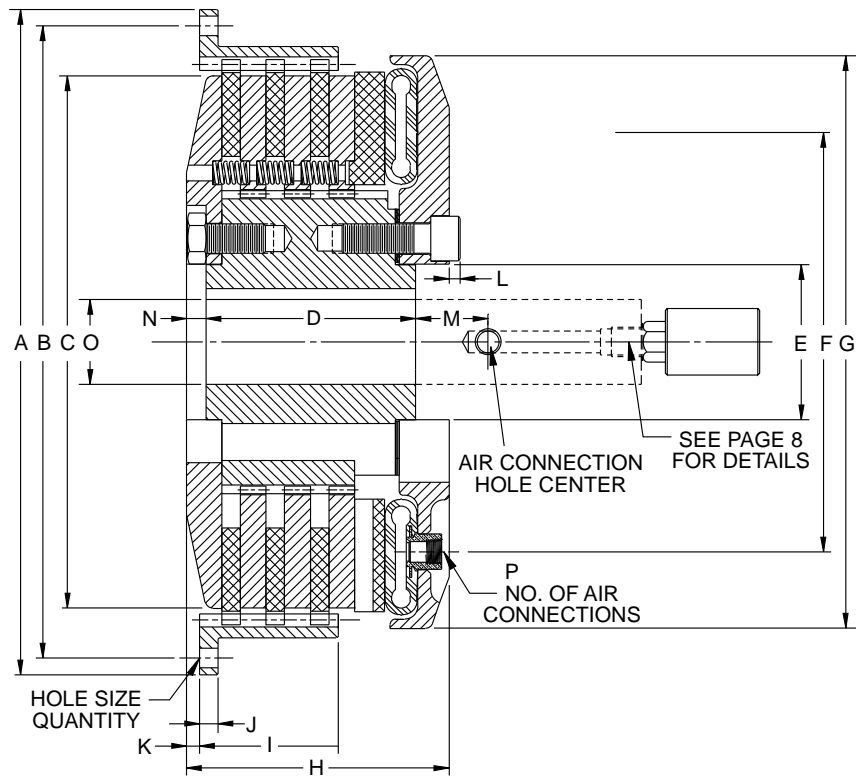

## DIMENSIONS inches (mm)

SIZE	A	B	HOLE SIZE	QTY	C	D	E	F	G	H	I	J	K
	+0.000/-0.005 (+0.000/-0.127)												
214H	18.375 (466.73)	17 1/4 (438.15)	17/32 (13.49)	8	14 (355.60)	5 3/4 (146.05)	4 1/2 (114.30)	12 1/2 (317.50)	16 5/16 (414.34)	6 1/2 (165.10)	2 3/8 (60.33)	1/2 (12.70)	3/4 (19.05)
314H	18.375 (466.73)	17 1/4 (438.15)	17/32 (13.49)	8	14 (355.60)	7 3/16 (182.56)	4 1/2 (114.30)	12 1/2 (317.50)	16 5/16 (414.34)	8 (203.20)	4 (101.60)	1/2 (12.70)	3/4 (19.05)
218	22.500 (571.50)	21 3/8 (542.93)	21/32 (16.67)	6	18 (457.20)	5 13/16 (147.64)	5 1/4 (133.35)	14 3/16 (360.36)	20 (508.00)	7 1/8 (180.98)	3 5/8 (92.08)	5/8 (15.88)	3/8 (9.53)
318	22.500 (571.50)	21 3/8 (542.93)	21/32 (16.67)	6	18 (457.20)	7 3/4 (196.85)	5 1/4 (133.35)	14 3/16 (360.36)	20 (508.00)	8 7/8 (225.43)	4 11/16 (119.06)	5/8 (15.88)	3/8 (9.53)
321	26.500 (673.10)	22 1/4 (571.50)	21/32 (16.67)	12	21 (533.40)	8 5/8 (219.08)	7 (177.80)	16 (406.40)	21 5/16 (541.34)	10 1/8 (257.18)	5 (127.00)	5/8 (15.88)	3/4 (19.05)



SIZE	L	M	N	O MIN	O MAX	P QTY
214H	-	2 1/4 (57.15)	-	2.13 (54.0)	3.25 (82.6)	2
314H	-	2 1/4 (57.15)	-	2.13 (54.0)	3.25 (82.6)	2
218	3/8 (9.53)	2 7/16 (61.91)	7/16 (11.11)	2.38 (60.3)	3.88 (98.4)	3
318	3/8 (9.53)	2 7/16 (61.91)	-	2.38 (60.3)	3.88 (98.4)	3
321	1 (25.40)	2 3/8 (60.33)	1/2 (12.70)	2.75 (69.9)	4.75 (120.7)	3

Driving ring mounts to standard SAE industrial flywheel.  
Larger bore sizes may be accommodated. Consult with WPT Engineering.

# Power Grip PO Clutches

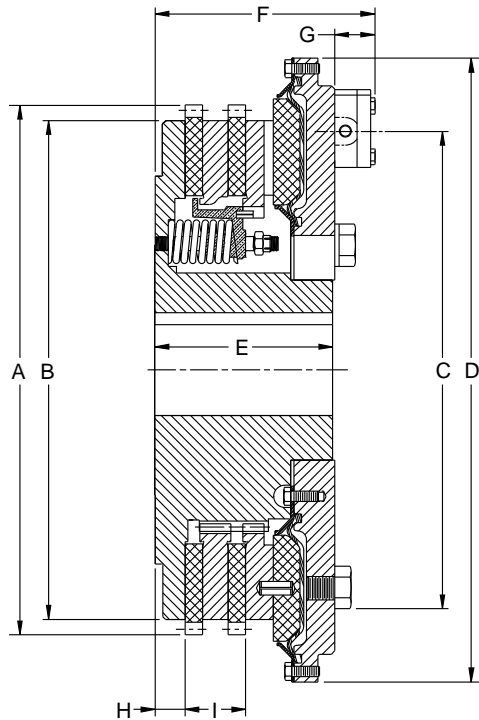

AIR CONNECTION  
1/4"-18 NPFT  
(2) AT 180"  
(1) ONLY ON 14"

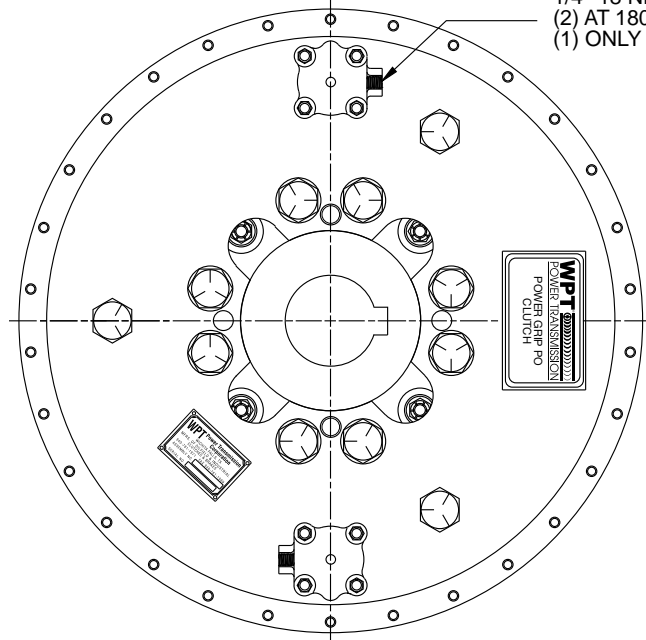

## DIMENSIONS inches (mm)

SIZE	A (ref only)	B	C	D	E	F	G	H	I
114	15 1/8 (384.2)	14 (355.60)	13 1/4 (336.55)	18 1/2 (469.90)	4 25/64 (111.52)	5 7/8 (149.23)	1 7/16 (36.51)	7/8 (22.23)	5/8 (15.88)
214	15 1/8 (384.2)	14 (355.60)	13 1/4 (336.55)	18 1/2 (469.90)	5 25/32 (146.84)	7 1/4 (184.15)	1 7/16 (36.51)	7/8 (22.23)	1 29/32 (48.42)
314	15 1/8 (384.2)	14 (355.60)	13 1/4 (336.55)	18 1/2 (469.90)	7 9/64 (181.37)	8 19/32 (218.28)	1 7/16 (36.51)	7/8 (22.23)	3 3/16 (80.96)
118	19 1/8 (485.8)	18 (457.20)	17 1/4 (438.15)	22 1/2 (571.50)	4 51/64 (121.84)	6 7/32 (157.96)	1 7/16 (36.51)	1 5/64 (27.38)	5/8 (15.88)
218	19 1/8 (485.8)	18 (457.20)	17 1/4 (438.15)	22 1/2 (571.50)	6 27/64 (163.12)	7 29/32 (200.82)	1 7/16 (36.51)	1 5/64 (27.38)	2 3/16 (55.56)
318	19 1/8 (485.8)	18 (457.20)	17 1/4 (438.15)	22 1/2 (571.50)	8 3/64 (204.39)	9 61/64 (252.81)	1 7/16 (36.51)	1 5/64 (27.38)	3 3/4 (95.25)
124	25 1/16 (636.6)	24 (609.60)	23 1/2 (596.90)	28 7/8 (733.43)	5 31/32 (151.61)	7 29/64 (189.31)	1 7/16 (36.51)	1 7/16 (36.51)	7/8 (22.23)
224	25 1/16 (636.6)	24 (609.60)	23 1/2 (596.90)	28 7/8 (733.43)	7 5/8 (193.68)	9 7/64 (231.38)	1 7/16 (36.51)	1 7/16 (36.51)	2 17/32 (64.29)
324	25 1/16 (636.6)	24 (609.60)	23 1/2 (596.90)	28 7/8 (733.43)	9 3/8 (238.13)	10 49/64 (273.45)	1 7/16 (36.51)	1 7/16 (36.51)	4 3/16 (106.36)
230	31 1/8 (790.58)	30 (762.00)	29 3/32 (738.98)	34 1/2 (876.30)	8 31/64 (215.50)	9 29/32 (251.62)	1 7/16 (36.51)	1 7/8 (47.63)	2 43/64 (67.87)
330	31 1/8 (790.58)	30 (762.00)	29 3/32 (738.98)	34 1/2 (876.30)	10 25/64 (263.92)	11 27/32 (300.83)	1 7/16 (36.51)	1 7/8 (47.63)	4 15/32 (113.51)

Certified prints available on request.

# Power Grip PO Clutches

## SPECIFICATIONS

Model	Torque Ratings @ 100 psi (lb-in)/7 bar (Nm)				Maximum Speed	Weight	Bore Range	
	Static Torque		Dynamic Torque				Minimum	Maximum
	lb-in	Nm	lb-in	Nm	rpm	lbs (kgs)	inches (mm)	inches (mm)
114	38,400	4,410	28,800	3,305	2,450	145 (66)	2.00 (50.8)	3.50 (88.9)
214	76,800	8,820	57,600	6,610	2,450	185 (84)	2.00 (50.8)	3.50 (88.9)
314	115,200	13,230	86,400	9,915	2,450	220 (100)	2.00 (50.8)	3.50 (88.9)
118	78,500	9,015	58,875	6,760	2,000	280 (127)	2.94 (74.6)	4.55 (115.6)
218	157,000	18,030	117,750	13,520	2,000	360 (163)	2.94 (74.6)	4.55 (115.6)
318	235,500	27,045	176,625	20,280	2,000	430 (195)	2.94 (74.6)	4.55 (115.6)
124	188,300	21,630	141,225	16,220	1,500	570 (259)	3.00 (76.2)	6.00 (142.4)
224	376,600	43,260	282,450	32,440	1,500	725 (329)	3.00 (76.2)	6.00 (142.4)
324	564,900	64,890	423,675	48,660	1,500	880 (399)	3.50 (88.9)	6.00 (142.4)
230	731,000	83,970	548,250	62,980	1,300	1,220 (553)	3.75 (95.3)	7.00 (177.8)
330	1,096,500	125,955	822,375	94,470	1,300	1,400 (635)	3.75 (95.3)	7.00 (177.8)

Consult WPT Engineering for application assistance and applicable safety/service factors.

TYPE A

TYPE B

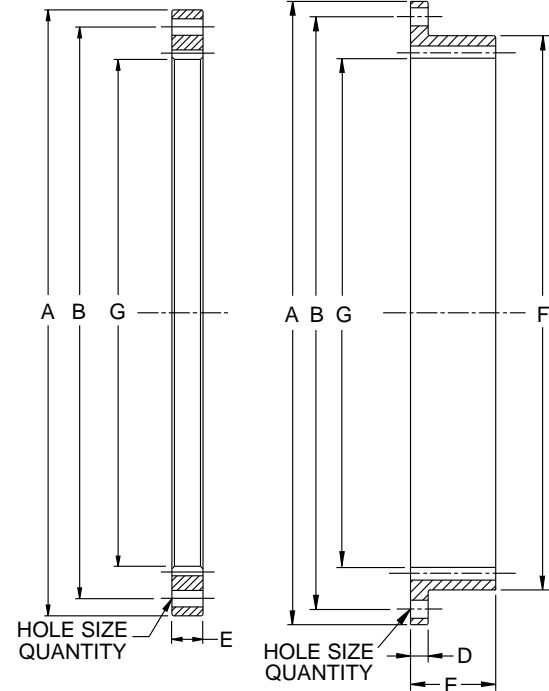

## DRIVE RING DIMENSIONS inches (mm)

SIZE	RING TYPE	A	B	C	D	E	F	G (ref only)	HOLE SIZE	QTY	NO. OF TEETH	WEIGHT lbs (kgs)
		+0.000/-0.005 (+0.000/-0.127)		+0.000/-0.005 (+0.000/-0.127)								
114	B	18.375 (466.73)	17 1/4 (438.15)	-	1/2 (12.70)	1 1/8 (28.58)	16 (406.40)	14 23/64 (364.7)	17/32 (13.49)	8	59	17 (7.7)
214	B					2 3/8 (60.33)						26 (11.8)
314	B					4 (101.60)						43 (19.5)
118	B	22.500 (571.50)	21 3/8 (542.93)	-	5/8 (15.88)	1 1/8 (28.58)	20 (508.00)	18 3/8 (466.7)	21 /32 (16.67)	6	75	24 (11)
218	B					3 1/16 (77.79)						43 (19.5)
318	B					4 1/4 (107.95)						55 (25)
124	A	28.875 (733.43)	27 1/4 (692.15)	-	3/4 (19.05)	1 1/2 (38.10)	25 7/8 (657.23)	24 25/64 (619.52)	25/32 (19.84)	12	99	65 (30)
224	B					3 1/2 (88.90)						67 (31)
324	B					5 1/2 (139.70)						88 (40)
230	C	34.750 (882.65)	33 (838.20)	32.000 (812.80)	1/8 (3.18)	4 1/2 (114.30)	-	30 23/64 (771.13)	25/32 (19.84)	12	123	230 (104)
330	C					7 (177.80)						361 (377)



- Plate separators and oversize release springs insure positive mechanical plate separation.
- No adjustments for the life of the friction material. Diaphragm compensates for wear.
- All clutches come standard with mechanical lockup feature for emergency use.
- Large diaphragm actuator provides more torque and minimizes release drag.
- Retained springs within the plate separator allow for easier servicing.
- Quick release valves are included on all clutches.

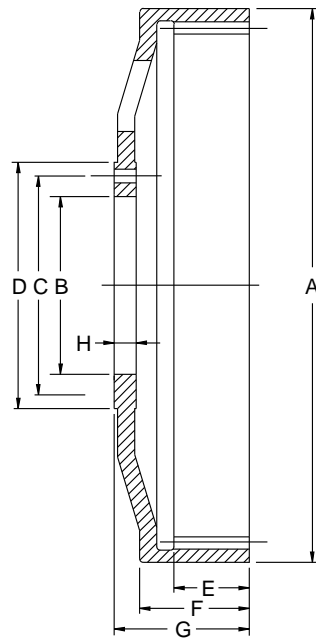
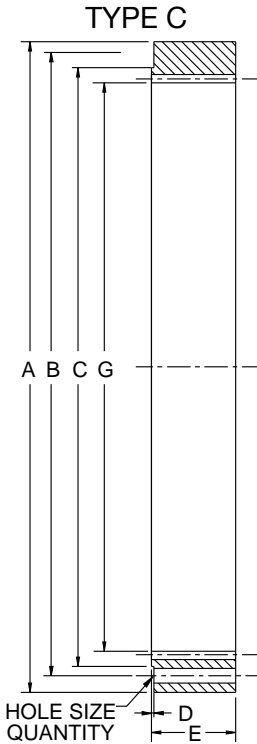

SPIDER FLANGE

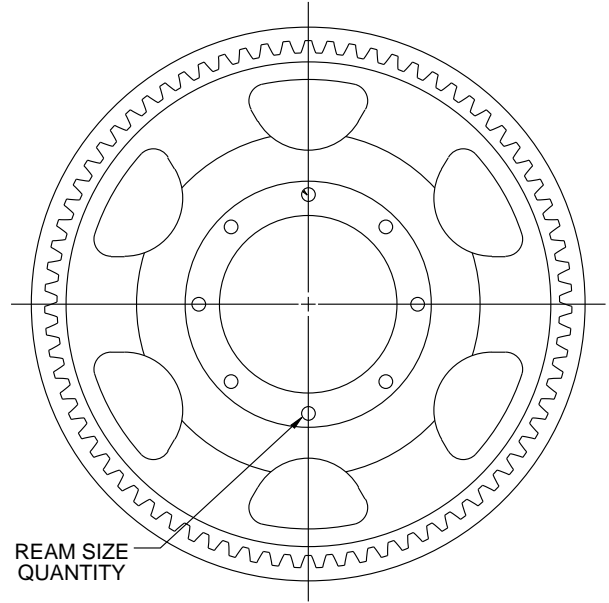

**SPIDER FLANGE DIMENSIONS inches (mm)**

SIZE	A	B	C	D	E	F	G	H	REAM SIZE	QTY	WEIGHT lbs (kgs)
		+ .002/- .000 (+ .051/- .000)									
114					7/8 (22.23)	2 1/16 (52.39)	3 1/8 (79.38)				27 (12.2)
214	16 (406.40)	6.500 (165.10)	8 (203.20)	9 (228.60)	2 1/4 (57.15)	3 7/16 (87.31)	4 1/2 (114.30)	5/8 (15.88)	.500 (12.70)	8	38 (17)
314					3 3/4 (95.25)	4 15/16 (125.41)	6 (152.40)				49 (22)
118					1 1/16 (26.99)	2 5/16 (58.74)	3 1/4 (82.55)				56 (25)
218	20 1/4 (514.35)	6.500 (165.10)	8 (203.20)	9 (228.60)	2 3/4 (69.85)	4 (101.60)	4 15/16 (125.41)	13/16 (20.64)	.500 (12.70)	8	82 (37)
318					4 1/8 (104.78)	5 3/8 (136.53)	6 5/16 (160.34)				99 (45)
124					1 3/8 (34.93)	3 1/4 (82.55)	4 1/2 (114.30)				121 (55)
224	26 1/4 (666.75)	8.000 (203.20)	10 (254.00)	11 1/2 (292.10)	3 1/4 (82.55)	5 1/8 (130.18)	6 3/8 (161.93)	15/16 (23.81)	.625 (15.88)	8	154 (70)
324					5 3/16 (131.76)	7 1/16 (179.39)	8 5/16 (211.14)				181 (82)

# ACCESSORIES

## Quick Release Valves (Springless)

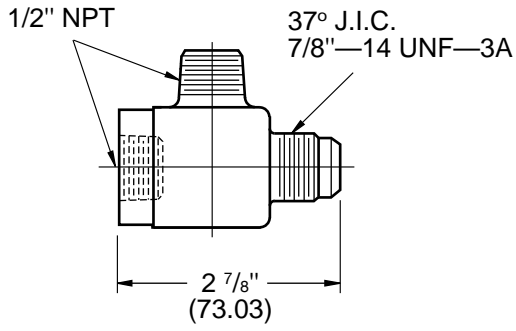

W00-10-900

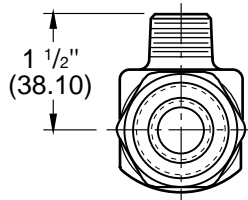

QRV

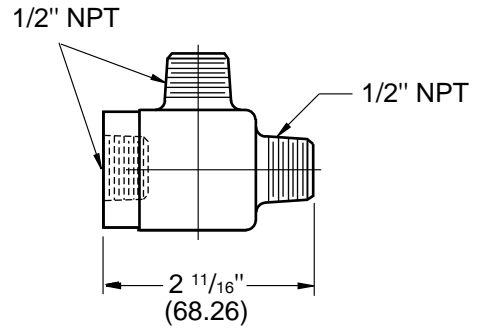

W00-10-901

(For applications not requiring QRVs, elbows are available.)

## Rotating Air Union Dimensions

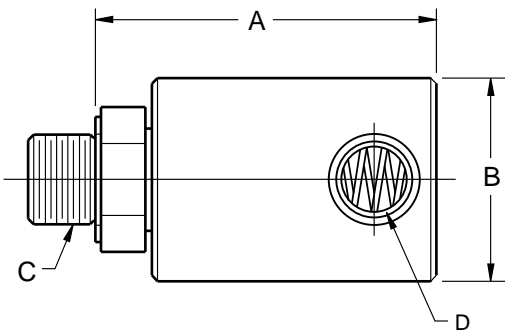

CLUTCH SIZE	Air Union Part Number	A inches (mm)	B inches (mm)	C Rotor Thread	D Inlet Thread
108 thru 318H	W00-21-006	2 5/8 (66.68)	1 5/8 (41.28)	5/8"-18 UNF	1/4" NPT
	W00-21-001	3 5/16 (84.14)	1 23/32 (43.66)	5/8"-18 UNF	3/8" NPT
121 thru 336	W00-21-002	3 23/32 (94.46)	2 1/4 (57.15)	1"-14 UNS	1/2" NPT/BSPT
	W00-21-008	4 5/16 (109.54)	2 7/8 (73.03)	1"-14 UNS	3/4" NPT
342 thru 460	W00-21-011	5 1/8 (130.18)	3 1/4 (82.55)	1 1/2"-12UNF	1" NPT

Larger capacity rotating air unions for faster response time available.

## Typical Hose Arrangements for Power Grip Clutches

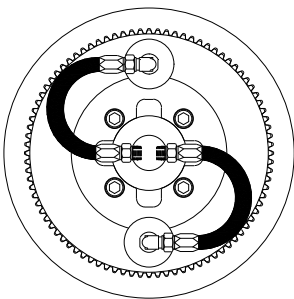

8" - 16"  
(1 or 2 Hoses)

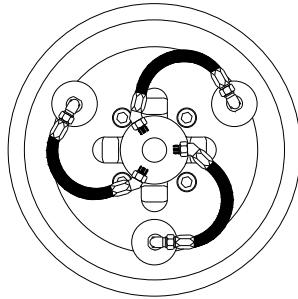

18" - 27"  
(1 or 3 Hoses)

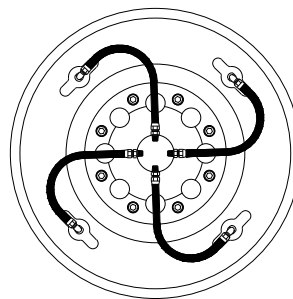

30" - 48"  
(4 Hoses)

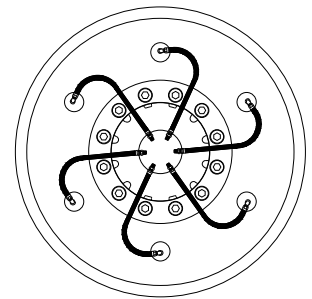

60"  
(6 Hoses)

# Heavy Duty Power Take-Off Clutches

## Hydraulic or Pneumatic Actuation

### Up to 2100 hp

Ideal for the following engine driven equipment:

- Pumps
- Woodchippers
- Recycling Shredders
- Dredges
- Road Planers
- Rock Crushers

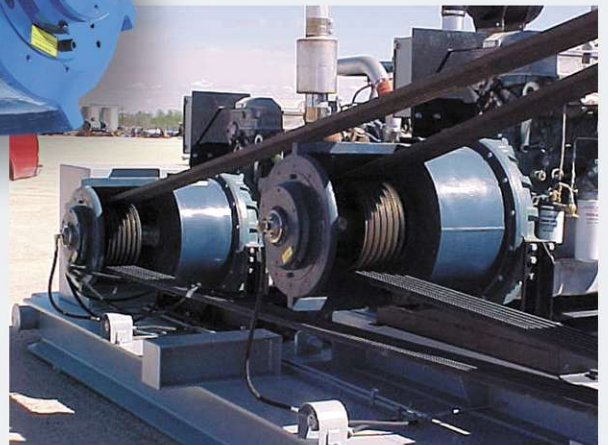

## Type 1

- Highest sideload capacity up to 2100 hp (1565 kW)
- Hydraulic actuation available
- Kevlar® reinforced friction discs
- No pilot bearing
- Self-adjusting
- Belt change without removing rear bearing

## Type 2

- Highest sideload capacity up to 700+ hp (520+ kW)
- Hydraulic actuation available
- Kevlar® reinforced friction discs
- No pilot bearing
- Remote engagement

For more information, request Brochure WLB-CG-000



## Worldwide Distribution

Consult our website for a distributor in your geographic region.

[www.WPTpower.com](http://www.WPTpower.com)

### WPT Power Corporation

1600 Fisher Road

P.O. Box 8148, Wichita Falls, TX 76305

phone: 940-761-1971 ♦ fax: 940-761-1989

email: [info@WPTpower.com](mailto:info@WPTpower.com)



ASSOCIATION OF  
EQUIPMENT  
MANUFACTURERS



Power  
Transmission  
Distributors  
Association