



# Type 2

If you are looking for an innovative, high capacity power take-off, look no further than the WPT® Type 2.

With its versatile design, dry clutch and top-of-the-line spherical roller bearings, the Type 2 PTO has been field-proven in many sideload applications.

The benefits of the WPT Type 2 include the potential for remote engagement, maintenance free self-adjusting clutch, with air or hydraulic actuation. Heavy-duty, laminated gear tooth friction discs are standard on 14" and 18" models. Bearings are lubricated with either grease or oil.

Customers needing maximum capacity in a small package will find the Type 2 an outstanding PTO for their applications.

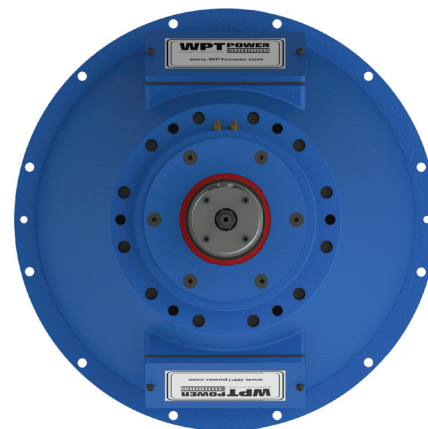
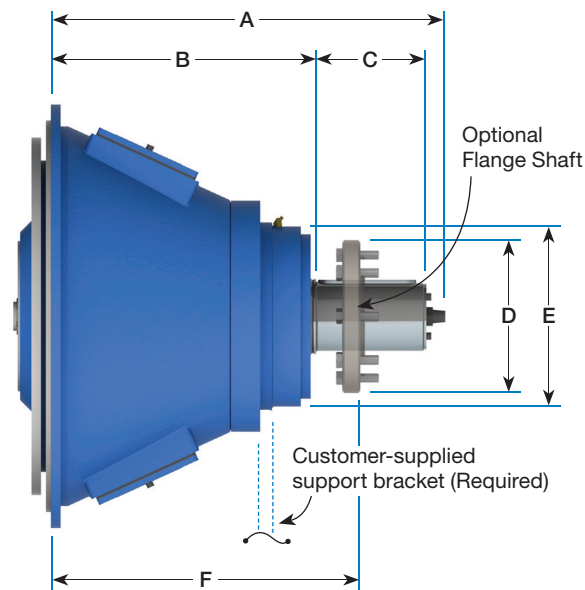

Model	SAE Housings	A	B	Output Shaft			Output Flange			D	E	F
				C	Dia	Keyway	Hole Circle	Qty	Thds			
211/311	3, 2	14 11/16 (373.1)	11 3/16 (284.2)	3 3/8 (85.7)	2.750 (69.85)	5/8 x 5/16 (15.9 x 7.9)	-	-	-	-	7 3/16 (182.6)	-
214/314H	1, 0	31 9/16 (801.7)	21 1/16 (535.0)	7 1/4 (184.2)	3.625 (92.08)	7/8 x 7/16 (22.3 x 11.1)	-	-	-	-	8 1/2 (215.9)	-
214/314H Compact	2, 1	20 7/16 (519.1)	13 5/8 (346.0)	5 9/16 (141.3)	3.543 (90.00)	.98 x .42 (25 x 10.7)	-	-	-	-	9 (228.6)	-
214/314H Flanged	1	26 1/2 (673.1)	-	-	-	-	4.75 (120.7)	6	5/8-18	6 1/2 (165.5)	8 1/2 (215.9)	21 7/8 (555.6)
218/318	0	31 7/16 (798.5)	21 7/16 (544.5)	7 1/4 (184.2)	3.625 (92.08)	7/8 x 7/16 (22.3 x 11.1)	-	-	-	-	8 1/2 (215.9)	-
218/318 Flanged	0	27 3/16 (690.6)	-	-	-	-	6.25 (158.8)	8	5/8-18	7 3/4 (196.9)	9 7/8 (250.8)	23 9/16 (598.5)
318 HD Flanged	0	23 3/4 (603.3)	-	-	-	-	8.75 (222.3)	16	3/4-10	10 1/2 (266.7)	12 (304.8)	21 1/8 (536.6)